



Design and Implementation of a Wireless Fluid Level Display System Using Ultrasonic Sensing Technique

Gesa F. Newton^{1*}, Terwase I. Aondona¹ and C. A. Chile²

¹*Department of Physics, University of Agriculture Makurdi, P.M.B. 2373, Benue State, Nigeria.*

²*Department of Physics, Benue State University, P.M.B. 102119 Makurdi, Benue State, Nigeria.*

Authors' contributions

This work was carried out in collaboration among all authors. Author GFN designed the research, the algorithm, developed the program codes in C, Author TIA made the schematics using Proteus software, simulated the designs and wrote the first draft of the manuscript. Author CAC did soldering, system testing and evaluation as well as proof-reading of the drafted manuscript. All authors read and approved the final manuscript.

Article Information

DOI: 10.9734/JERR/2020/v14i117116

Editor(s):

(1) Dr. Ravi Kant, Maharaja Ranjit Singh Punjab Technical University, India.

Reviewers:

(1) Shashikant Sadistap, Central Electronics Engineering Research Institute, India.

(2) Anak Agung Ngurah Gunawan, Universitas Udayana, Indonesia.

Complete Peer review History: <http://www.sdiarticle4.com/review-history/58077>

Original Research Article

Received 14 April 2020

Accepted 20 June 2020

Published 30 June 2020

ABSTRACT

The wireless fluid level indicator comprises a sensing and transmitting circuit for detecting and transmitting the levels of fluids from a container to the receiving circuit which receives and displays the amount of the measured volume. This has been achieved using an ultrasonic sensor (HC-SR04), a firmware (PIC16F648A/PIC16F876A microcontroller programmed in C/assembly languages), an encoder (HT12E) and a radio frequency (RF) transmitter transmitting at a bandwidth of 433MHz to an RF receiver interfaced with a decoder (HT12D), liquid crystal display (LCD) and a Buzzer. The device when tested measured water levels and transmitted same over a distance of up to 98.5 meters in open areas and up to 50 meters in highly obstructed areas. The average response time was also estimated to be 0.1 second. As a contact-less depth detection system, the device finds useful applications in measurement of fluid levels in homes and industries where concentrates, table water, transmission oils are produced, without affecting the chemical or physical properties of such substances-an advantage over the contact methods used in fluid level detection.

Aims: To design and implement a wireless microcontroller based fluid level display system using ultrasonic sensing method.

*Corresponding author: Email: gesnewx@yahoo.co.uk;

Study Design: By encoding the Transmitter module to sense and detect the amount of water level, while the decoder module decodes the received data and display the result.

Place and Duration of Study: Department of Physics, University of Agriculture Makurdi, Benue State, Nigeria, between November 2018 and April 2019.

Methodology: An RF transceiver, encoder/decoder (HT12E/HT12D), a 2x16 Liquid display module, 4MHz crystal oscillator, a buzzer and other peripherals were interfaced to two 8-bit controllers; PIC16F648A and PIC16F876A. The controllers were programmed in C/Assembly languages to enable effective communication of the system. The system was then calibrated to read and transmit water level values from a 30-centimeter deep tank over a distance of 1.0 - 98.5 meters.

Results: The system was tested to have maximum sensitivity over a distance of 98.5 meters in non-obstructed areas and 50 meters in obstructed areas. The average response time was also estimated to be 0.5 seconds.

Conclusion: The design and implementation of a wireless fluid level display system using ultrasonic sensing technique has been successfully done. The system workability is suitable for deployment and usage in domestic and industrial purposes.

Keywords: Wireless; fluid level; ultrasonic-sensor; microcontroller.

1. INTRODUCTION

In most places and systems where fluids are stored and used, fluid management systems are designed in a way that the level of fluid may be easily seen with the naked eyes - for those in open surfaces and transparent containers. However, in opaque containers and closed systems such as overhead tanks, visualizing the fluid level becomes a difficult task and requires technological application. To monitor the fluid level/content in most such fluid systems, called fluid level indicators like float level indicators or mechanical float gauges could be used. The origin of these devices can be traced back from the discovery of electron by J.J Thompson down to solid state devices where transistors and microprocessors used in the design of electronic devices arose [1,2].

Nowadays, with more technological innovations, proper monitoring and management of fluid could be achieved using electronic devices such as, tempo-sonic sensors, fluid alarms and ultrasonic level detectors. Some of these fluid level indicators are contact based and hence have their own limitations and side effects. These shortcomings include corrosion of metal parts leading to less reading accuracy of the instruments, as well as contamination of such fluids. Also, the proximity of these devices to the containing vessels introduces the burden of continuous check by the user vis-a-vis fluid levels. This can be a stressful exercise. Also, contact based indicators has become a lagging technology which requires an upgrade. The numerous setbacks created and encountered in

these contact based fluid level indicators and other ineffective and inefficient fluid level indicators have generated a problem which needs to be addressed.

This research focuses on the design and implementation of a wireless microcontroller based fluid level sensing and display system which entails the assembling of components such as ultrasonic sensors, transistors, radio frequency transmitters and receivers with a microcontroller interfaced to determine, process and display accurately the level of fluid in a container. This would enhance fluid level monitoring which in turn minimizes wastage of fluids (e.g. water) during pumping process. Additionally, the accurate determination of fluid level in the septic tanks would eliminate emergency run-out of water in homes or industries. Hence, this research emphasizes the application and utilization of electrical and electronic theories, methods and techniques for effective determination of fluid levels by considering a wireless transmission mode communication between the interfaced component units.

1.1 Review of Related Works

Reza et al. [3] designed a microcontroller-based automatic water level sensing and controlling device to monitor and manage water utilization [3]. The system was implemented based on the contact-method of fluid detection. The variation of water conductivity with change of depth was deployed in which an LED indicated the different water levels. The device offered a good water control measure.

Another work presented by Ayob et al. [4] uses the contact method of fluid sensing via sensing probes interface to a microcontroller (PIC16F877A) circuitry. To keep tracked of the measure and processed water level, the global system of mobile (GSM) communication network was deployed to send short messages (alerts) to the user [4]. To achieve the level transmission, a GSM module was interfaced to MAX232 thereby providing a hyper-terminal protocol that checks the microcontroller operation.

In another related research, Ejiofor and Oladipo [5] presented a microcontroller based automatic water level control system where the work of detecting the level of water was done by LM324 comparator. An AT86C52 microcontroller was used to control the functionality of the entire system [5]. As a contact method, the circuit relied on copper conductors to transfer voltage to the comparator circuit and the microcontroller. The status is then displayed on an LCD screen while utilizing relays in the switching circuit to trigger ON or OFF the pump depending on the water level.

More so, by using contact method; Naregalkar et al. [6] designed a wireless water level indicator. In the work, a PIC 16F877A microcontroller was interfaced with sensing probes and then programmed to monitor the water level of an overhead tank placed up to 100 meters away. Using a radio frequency system the measured and processed water levels were put across to the user [6]. However, the sensing probes placed in the water have a tendency of affecting the purity of the water through corrosion leading to rusting in the long run.

1.2 Sensors

A sensor is a device that takes in the input signal by detecting events or changes in its environment and then producing a corresponding output. Though different types of sensors have their own mode of operation but generally a sensor acts as a transducer by acquiring a

physical quantity (such as sound and temperature) and converts it into a signal (such as optical, electrical or mechanical form) suitable for processing through some physical principles such as Ampere's law, Curie-Weiss law, Faraday's law of induction and photoconductive effect e.t.c. and the active element of a sensor is called a transducer which is a device that converts one form of energy to another [7].

1.2.1 Ultrasonic sensors

Ultrasonic sensors are based on the measurement of the properties of acoustic waves with frequencies above the human audible range often above 20 KHz. They typically operate by generating a high-frequency pulse of sound and then receiving and evaluating the properties of the echo pulse. Ultrasonic sensors are based on the three physical principles: Time of flight, sensing velocity and amplitude attenuation [7]. Of these categories, only the time of flight ultrasonic sensor is of interest in this work.

Time of flight (for sensing distance): it can be in reflection mode or direct measurement mode. In reflection mode (echo ranging) considered in this work, the transmitter emits a short burst of sound in a particular direction which the pulse on bouncing off a target it returns to the receiver after a time interval, while the receiver records the length of this time interval (high level time) and calculates the distance travelled based on the speed of sound in air as shown in Fig. 1.

The total distance travelled by the burst is 2X (forward and backward). The sensing (Test) distance is thus obtained as in equation 1.

Sensing (Test) distance = (high level time × speed of sound in air)/2 [8].

1.3 Microcontroller

A microcontroller is a compact microcomputer designed to govern the operation of embedded systems in most electrical devices.

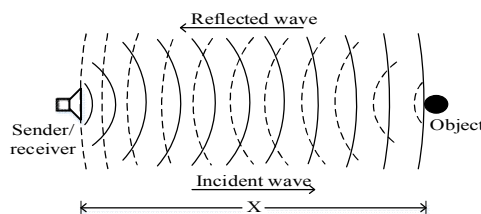

Fig. 1. An ultrasonic wave with transmitter joined to a receiver [7]

PIC microcontrollers are a common family of microcontrollers produced by microchip technology that uses simple microcode stored in ROM to perform its tasks [9]. The pin configuration of PIC16F87XA and PIC16F648A microcontrollers is shown in Fig. 2.

2. METHODOLOGY

The wireless fluid level detection system in this work was designed and implemented according to the block in Fig. 3.

2.1 Hardware

2.1.1 Power supply unit

This provides the required power supply for the microcontroller, liquid crystal display, encoder/decoder, ultrasonic sensor as well as transmitting and receiving modules. To achieve the power supply, a 9V DC battery source is regulated via LM7805 voltage regulator to produce a +5V supply (Vcc). Using a 0.1pf (mica) and 100µf (electrolytic) capacitors, the transients/ripples are mitigated to produce a clean dc suitable for efficient system operation. The circuit design is presented in Fig. 4.

2.1.2 Input (sensing) unit

This unit is responsible for the sensing and detection of the fluid level. To achieve this, an ultrasonic transceiver (HC-SR04) was used. The transceiver sends ultrasonic waves (SONAR) into the container (via TRIG pin) and then detects the reflected waves as echo (via ECHO PIN) due to the fluid surface. The distance covered by the sonar within the computed time of flight, corresponds to the distance of target. The ultrasonic sensor is chosen because of its ruggedness, non-intrusive nature which does not affect the purity of the fluid and its long range sensitivity (2 cm to 400 cm) with an accuracy of

3mm. The circuit design of this unit is shown in Fig. 5. Using equation 1 as compiled in C, the microcontroller (PIC16F648A) processes the depth of the fluid. Table 1 shows the detailed specification of the ultrasonic sensor used in this work.

2.1.3 Processing section

2.1.3.1 Transmitter unit

The unit comprises an RF transmitter module (ASK Tx) linked up with a 4-bit encoder (HT12E) interfaced to a microcontroller (PIC16F648A). The processed data is extracted from the PIC16F648A through the input pins (AD8 – AD11) whenever the trigger pin (TE) is ON. The data is then sent out to the user end by the RF module through its antenna at a frequency of 433MHz. This frequency is used as specified by the data sheet been one of the carrier frequencies commonly used and commercially available. The HT12E encoder is commonly used in RF applications due to its 4bit – input/output data conversion (from pins AD8 – AD11 to D_{OUT}). Moreover, its low power and high noise immunity CMOS technology with low standby current of 0.1µA at VDD=5V [10] make it a suitable device for remote-based applications. The 820kΩ resistor provides the necessary external resistance for the internal oscillator of the encoder as prescribed by the datasheet. The PIC16F648A microcontroller is chosen due to its low cost and suitability for embedded systems. The circuit design of the transmitting section is shown in Fig. 6.

2.1.3.2 Receiver unit

The receiver unit consists of an amplitude shift keying (ASK) RF receiver module linked up with a 4-bit decoder (HT12D) and interfaced to an 8-bit microcontroller (PIC16F876A). This device

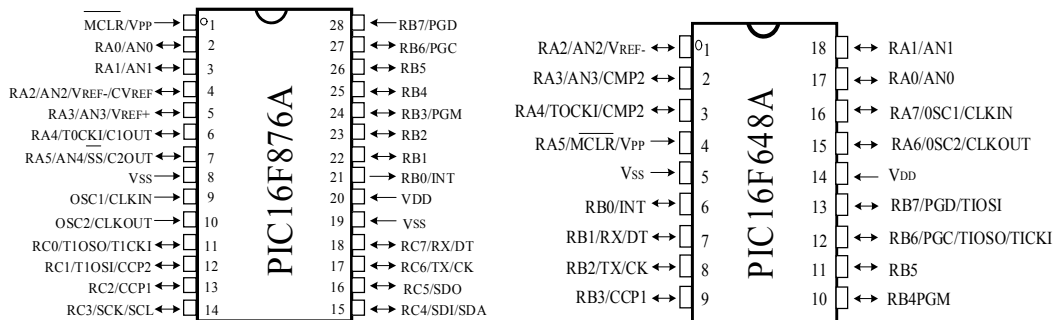

Fig. 2. Pin configuration of PIC16F876A and PIC16F648A microcontrollers

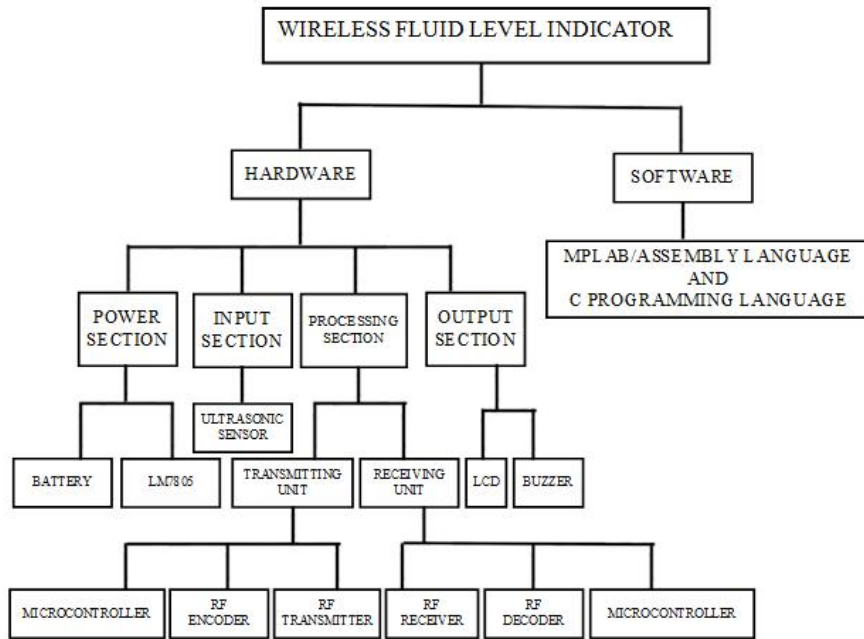

Fig. 3. Block diagram for the implementation of a wireless fluid level indicator

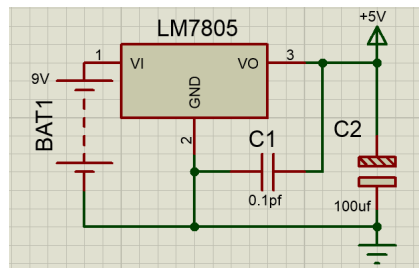

Fig. 4. Circuit design of the power supply unit

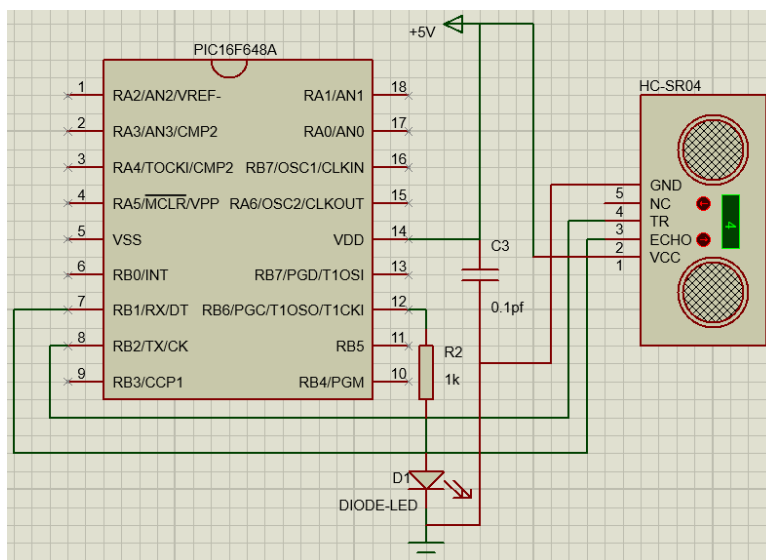
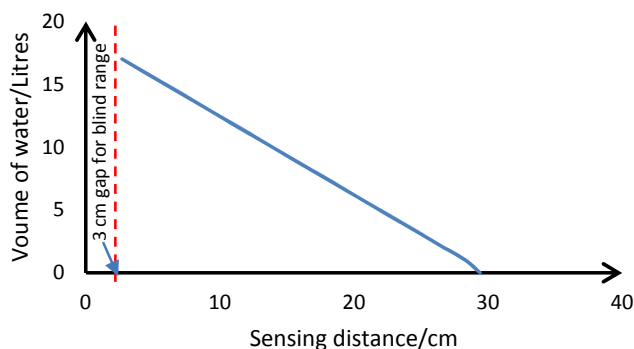

Fig. 5. Circuit design for the HC-SR04 ultrasonic transceiver

Table 2. Test results for the regulated power supply

Specified voltage (LM7805)	5.00V
Voltage-No-Load	4.99V
Voltage-Full-Load	4.90V

**Fig. 11. Readings from sensor test**

4. CONCLUSION

The microcontroller-based wireless fluid level display system using ultrasonic sensing technique was successfully designed and implemented. Compared with other conventional designs; the wireless fluid level controller shows good performance and is more effective, reliable and cheap. The system is designed in such a way that it will be able to prevent the wastage of water and transmits the different water levels wirelessly to a receiver system placed some distances away from the containing vessel. The whole system operates automatically and thus; does not need manual intervention compared to other conventional contact methods of water level monitoring. It is noteworthy that moisture (humidity) has minimal effect (0.036% / 10% RH change) on ultrasonic sensors unlike photoelectric sensors. Hence the model used in this work is designed to withstand the harsh outdoor environment with full epoxy potting, UV shielded cables and stainless steel housing. To avoid cases of fluid spill when filling of tank, overflow control pipes or automatic ON/OFF circuit could be included to control the pump with respect to maximum desired fluid level thereby forestall any case of spillage which could affect the performance of the sensor.

COMPETING INTERESTS

Authors have declared that no competing interests exist.

REFERENCES

1. Franco Maloberti, Anthony C. Davies, editors. A Short History of Circuits and Systems; 2016. [ISBN: 978-87-93379-70-1 (Paperback) 978-87-93379-71-8 (Hardback) 978-87-93379-69-5]
2. Gaur RK, Gupta SL. Engineering Physics. 1981: pp 54, Reviewed 2014. Ish Kapur for Dhanpat R.
3. Reza SM, Shah A, Tariq SM, Reza M. Microcontroller based automated water level sensing and controlling: Design and Implementation Issue, Proceedings of the World Congress on Engineering and Computer Science. 2010;1:220-224.
4. Ayob J, Mohd HA, Nur SL, Ayob EM, Ayob IM, Ayob AM, Mohd NH. Tank water level monitoring system using gsm network. (IJCSIT) International Journal of Computer Science and Information Technologies. 2011;2(3):1114-1120.
5. Ejiofor VE, Oladipo OF. Microcontroller based Automatic Water level Control System, International Journal of Innovative Research in Computer and Communication Engineering. 2013;1(6): 1390-1396.
6. Naregalkar PR, Nishtha J, Parag V, Piyush B. Wireless water level indicator and controller using PIC microcontroller. International Journal of Current Research. 2016;8(02):26680-26683.

7. Regtien PPL. Sensors for mechatronics. Elsevier, USA; 2012.
8. Elijah J. Morgan. HC-SR04 Ultrasonic Sensor; 2014.
9. Microcontroller chip Technology. PIC16F87XA Datasheet; 2001. Available:www.microchip.com
10. Holtek. HT12A/HT12E Data Sheet for 2¹² Series of Encoders. 2000. Retrieved On 12th January; 2017.
11. Holtek. HT12D/HT12F Data sheet for 2¹² Series of Decoders. 1999. Retrieved on 12th January; 2017
12. Álvaro Hernández, Jesús Ureña, Manuel Mazo, Juan J. García, Ana Jiménez, Fernando J. Álvarez. Reduction of blind zone in ultrasonic transmitter/receiver transducers. Sensors and Actuators A: Physical. 2007;133(1).

APPENDIX

Plates of the Research Work

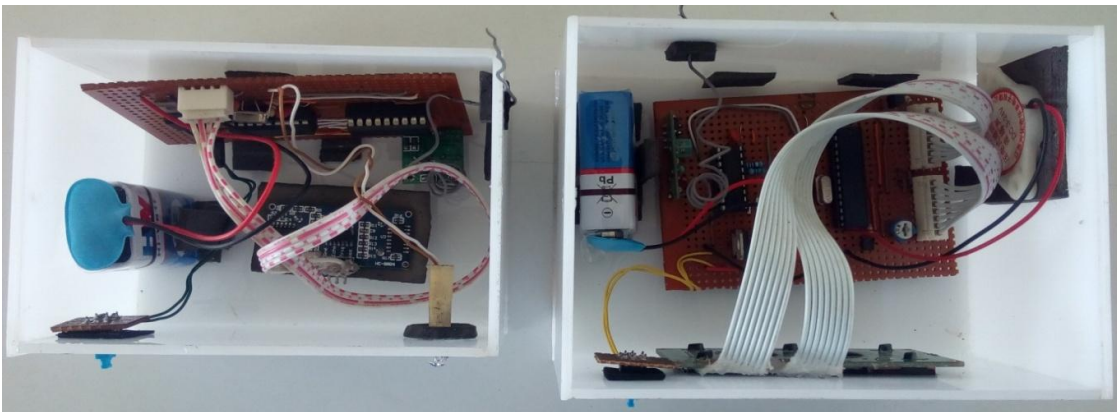

Plate 1. Top view of Implemented wireless fluid level display system

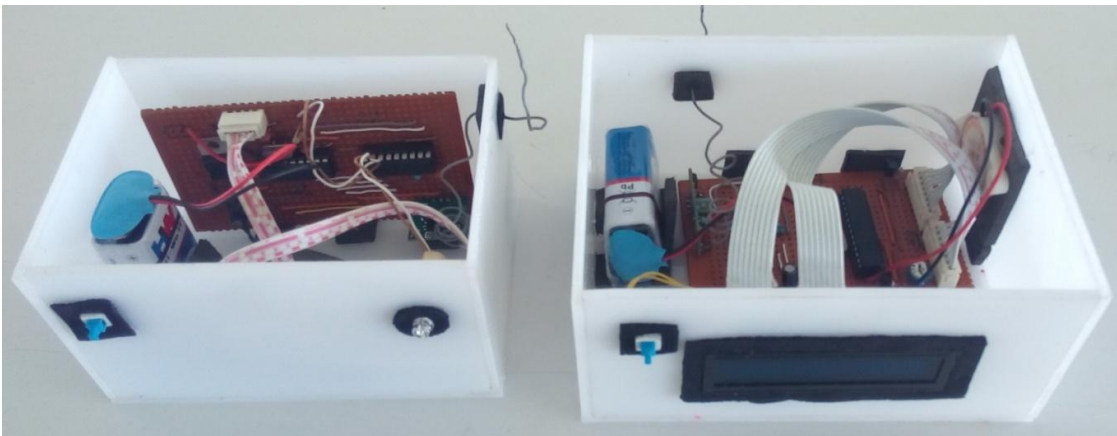

Plate 2. Front view of Implemented wireless fluid level display system

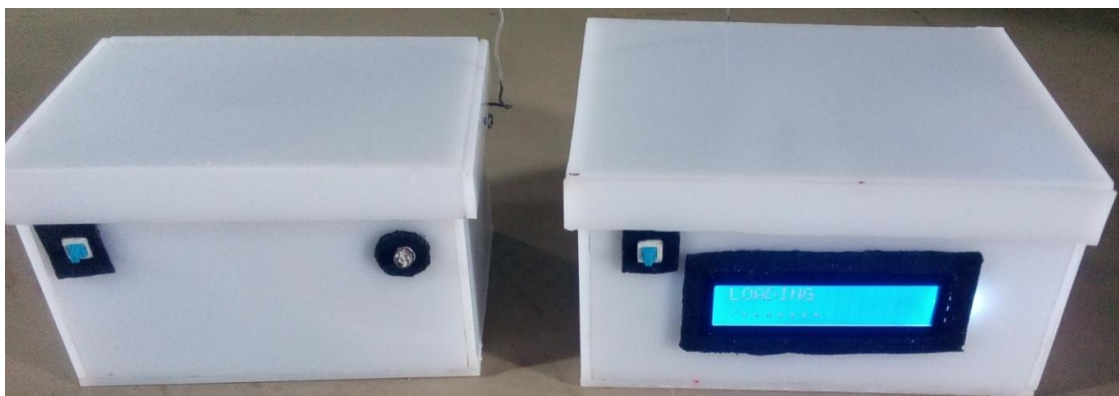

Plate 3. A view of the transmitter and receiver units

© 2020 Gesa et al.; This is an Open Access article distributed under the terms of the Creative Commons Attribution License (<http://creativecommons.org/licenses/by/4.0>), which permits unrestricted use, distribution, and reproduction in any medium, provided the original work is properly cited.

Peer-review history:
The peer review history for this paper can be accessed here:
<http://www.sdiarticle4.com/review-history/58077>