



A Study on Evolution of Optical Fiber Communication from PDH to SDM Technology

Panchali Datta Choudhury ^{a++*} and Tanmay De ^{b#}

^a Brainware University, Kolkata, India.

^b National Institute of Technology, Durgapur, India.

Authors' contributions

This work was carried out in collaboration between both authors. Both authors read and approved the final manuscript.

Article Information

DOI: <https://doi.org/10.9734/cjast/2024/v43i74413>

Open Peer Review History:

This journal follows the Advanced Open Peer Review policy. Identity of the Reviewers, Editor(s) and additional Reviewers, peer review comments, different versions of the manuscript, comments of the editors, etc are available here: <https://www.sdiarticle5.com/review-history/119712>

Review Article

Received: 16/05/2024

Accepted: 18/07/2024

Published: 23/07/2024

ABSTRACT

In today's world, long distance communication is a vital part of communication technology. In the field of communication, continuous research is going on for transmission of a greater number of bytes. In this article we discuss the different stages of long-distance communication via optical fiber and we go through the history of optical fiber communication and discuss the different stages of development in the optical fiber communication. This article briefly discusses the following stages of optical fiber communication: i) Plesiochronous Digital Hierarchy (PDH) ii) Synchronous Digital Hierarchy (SDH) iii) Wavelength Division Multiplexing (WDM) iv) Elastic Optical Networks (EONs) v) Space Division Multiplexing (SDM).

⁺⁺ Associate Professor;

[#] Professor;

^{*}Corresponding author: E-mail: panchali.dc@gmail.com;

Cite as: Choudhury, Panchali Datta, and Tanmay De. 2024. "A Study on Evolution of Optical Fiber Communication from PDH to SDM Technology". *Current Journal of Applied Science and Technology* 43 (7):140-60. <https://doi.org/10.9734/cjast/2024/v43i74413>.

Keywords: Optical fiber; voice frequency; frequency modulation; coaxial cable; PCM cables; fiber cables.

ABBREVIATION

ANSI : American National Standards Institute
ATM : Asynchronous Transfer Mode
BV-OXC:Bandwidth Variable Optical Cross-Connect
BV-WSS:Bandwidth Variable Wavelength Selective Switches
BV-T : Bandwidth Variable Transponder
CCITT : Consultative Committee for International Telephony and Telegraphy
DQDB: Distributed-Queue Dual-Bus Network
EONs : Elastic Optical Networks
FDDI : Fiber Distributed Data Interface
ITU-T :International Telecommunications Union Telecommunication Standard- ization Sector
LASER :Light Amplification by Stimulated Emission of Radiation
PCM : Pulse Code Modulation
PDH : Plesiochronous Digital Hierarchy
ROADM:Reconfigurable Optical Add-Drop Multiplexer
SBVT :Sliceable Bandwidth Variable Transponder
SDH : Synchronous Digital Hierarchy
SDM : Space Division Multiplexing
SOH : Section Overhead
SONET: Synchronous Optical Networking
STM : Synchronous Transport Module
WDM : Wavelength Division Multiplexing

1. INTRODUCTION

In this article, we are going to discuss in nutshell the different stages of optical fiber communication and how the research work is continuously going on for increasing the number of channels in different directions.

Before going to discuss communications through the optical fiber, let us look back to the history of communications.

The first stage of communication started after the invention of the telephone by the great scientist Alexander Graham Bell. While the telephone transmitter converted voice energy to electrical energy, the receiver converted electrical energy to voice energy. The voice frequency range is 0.3 to 3.4 KHz. Due to fading, the conversation with voice frequency was only possible within a limited distance and soon research started for long-distance communications. The first step was

using a higher frequency as the carrier for carrying the voice frequency by the process of modulation. This resulted in the evolution of Amplitude Modulation, Frequency Modulation, and Phase Modulation [1].

Step by step long-distance communication started with three channel carrier system, eight channel carrier systems, and twelve channel carrier system with the help of overhead wires. These overhead systems were unable to go beyond a certain distance and at the same time were unable to increase the number of channels. Then with the invention of coaxial cable (which can be laid underground) and coaxial system, communication of a few thousand channels to far more distance was possible. Simultaneously, research work was continuously going on for wireless long-distance communication with fruitful communication via microwave, but at that time, communication through coaxial cable or microwave was analog. The main disadvantage of the analog system was noise. The real revolution in communication started after the invention of Pulse Code Modulation (PCM) [2] which enabled digital communication. It has been observed that almost Noise-free communication is possible only through digital communication. The theory of amplitude, frequency, and phase modulation in the analog system effectively resulted in Amplitude Shift Keying (ASK), Frequency Shift Keying (FSK), and Phase Shift Keying (PSK) in digital system [3].

Short-distance digital communication started with PCM cables and long-distance communication started through the digital microwave. Another revolutionary evolution was using satellite transponder [4] for long-distance communication via satellite communication system.

All the above communication systems were limited to a finite number of channels. Every passage of time was putting pressure on the communication system to increase the number of channels. All the above pressure resulted in the invention of optical fiber cable and optical fiber communication.

The initial consideration was the high-speed of optical energy in travelling a very long distance and having a very wide bandwidth. Then the

research for converting electrical energy to optical energy and vice-versa resulted in the evolution of source and detector.

2. DEVELOPMENTS IN OPTICAL FIBER COMMUNICATIONS

In this section, we are going to discuss briefly the developments in optical fiber communication and the continuous increase of communication for larger number of channels through the optical fiber. A simple block diagram of digital communication through an optical fiber is shown in Fig. 1. Before discussing different stages of optical fiber communication, let us have a bird's eye view of fiber optics.

Alexander Graham Bell attempted using light for carrying information in 1880, but that was limited to a very short distance. In early 1950, an important breakthrough was made in the field of fiber optics for the manufacture of optical fiber cable [3].

The LASER (Light Amplification by Stimulated Emission of Radiation) was invented in 1960. The invention of LASER greatly accelerated research efforts in fiber optics communications. The fiber cables available in 1960 were extremely lossy (loss more than 1000 db/km), and with this loss, optical fiber communication was not possible [3]. Continuous research work has reduced the loss in the fiber cables tremendously in 10 years. In 1970, fiber cables were available with a loss of nearly 20 db/km, but continuous research work on fiber cables has resulted in the manufacture of present-day cables having very negligible loss/km.

The main advantages of optical fiber communications are as follows:

- enormous potential bandwidth
- small size and weight
- electrical isolation
- immunity to interference and cross-talk
- signal security
- ruggedness and flexibility
- potential low cost

3. AN OVERVIEW OF PHYSICAL CHARACTERISTICS OF OPTICAL FIBER CABLE, INFRARED SPECTRUM AND REGENERATOR

An optical fiber consists of a very fine cylinder of glass (core) through which light propagates. The core is surrounded by a concentric layer of glass (cladding) which is protected by a thin plastic jacket.

The refractive index of the core is kept at slightly higher than the refractive index of cladding so that due to total internal reflection, all light passes through the core only.

The optical fiber cable is of two types: single-mode fiber and multi-mode fiber [5]. The multi-mode fiber has a typical core diameter equal to $50\mu\text{m}$ or $62.5\mu\text{m}$ and cladding diameter equal to $125\mu\text{m}$. The single-mode fiber has a typical core diameter equal to $9\mu\text{m}$, and cladding diameter equal to $125\mu\text{m}$.

Due to a larger core diameter, multi-mode fiber is much cheaper than single-mode fiber. The problem in multi-mode fiber is that light cannot move in a straight line, it moves in different directions causing interference and ultimately causing attenuation (loss).

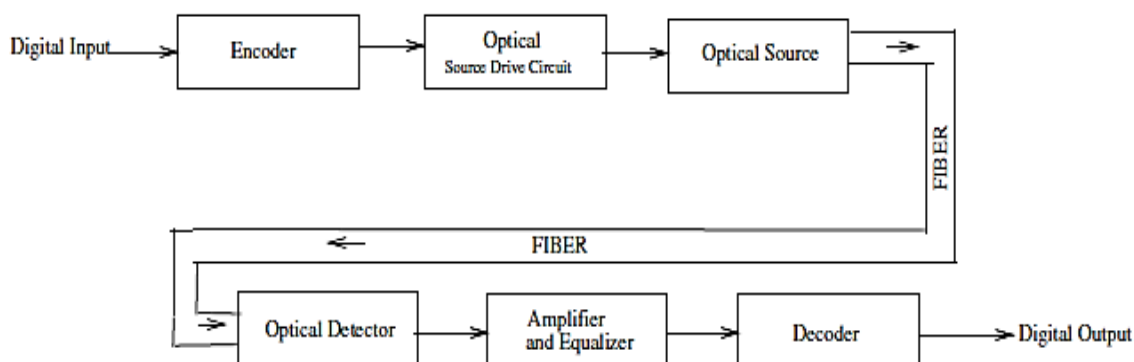

Fig. 1. A simple block diagram of digital communication through an optical fiber

The single-mode fiber is costlier than multi-mode fiber but due to very small core diameter light moves in a straight line causing very little attenuation. Due to the above reasons, multi-mode fiber is used for very short distance communications. For long-distance communications where the requirement is a transmission of a large number of bit-rate, only a single-mode fiber is used. The initial stages of research decided that the optical fiber communications will be limited to the infrared spectrum (above visible spectrum) of the electromagnetic spectrum.

Light consists of different colors and each color has a different wavelength. Initially, it was decided through research work, which window of the infrared spectrum should be used for optical fiber communications, and the following three windows were fixed:

1. First window has a wavelength of 850nm.
2. Second window has a wavelength of 1310 nm.
3. Third window has a wavelength of 1550nm.

The first window has more attenuation while the third window has the least attenuation. The

wavelength of 850 nm is generally used for short-distance communications using multi-mode fiber. For long-distance communications, 1310 nm and 1550 nm are used. When transmission requires a high bit-rate, a wavelength of 1550 nm is used. An important point in long-distance communication is regeneration [6]. Attenuation is dependent on distance, so attenuation increases while travelling a long distance. After some specific distance regeneration is essential so that no information is lost in propagation.

Before establishing a link between two long-distance stations, it is decided by calculation at what interval of distance regenerators must be placed. The purpose of using a regenerator is to reproduce the actual signal.

4. BRIEF DISCUSSION ON PDH MULTIPLEXING

Long-distance communication through optical fiber started with PDH (plesiochronous digital hierarchy) systems [7]. PDH systems are based on 24/30 channels PCM (Pulse Code Modulation) system and all the existing digital systems were working on PDH systems.

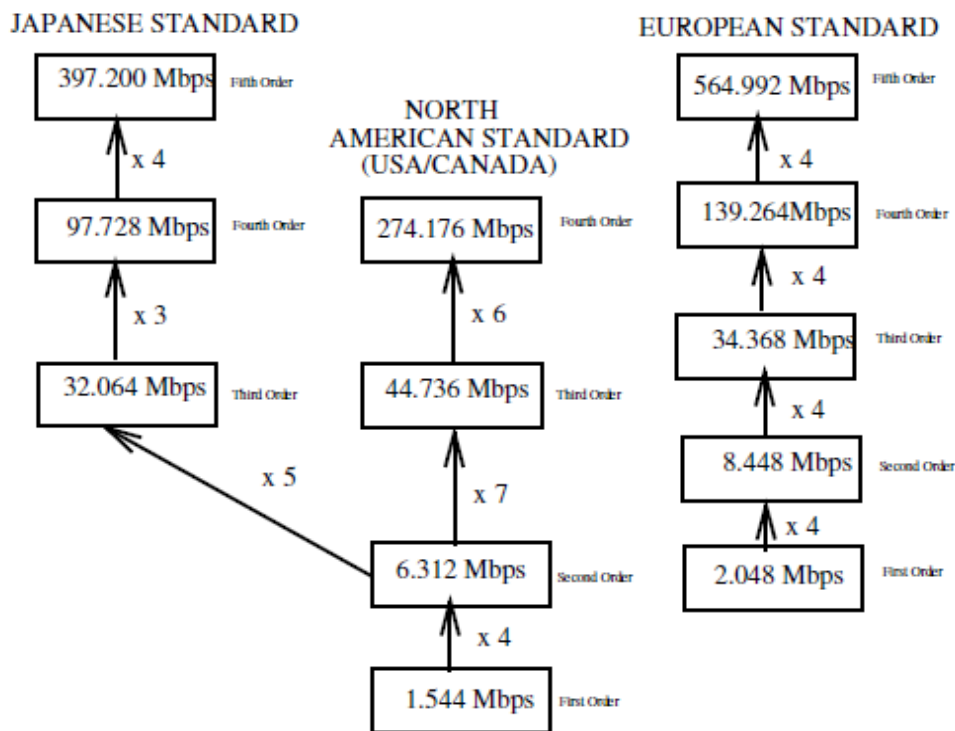

Fig. 2. Multiplexing tree for different PDH Hierarchies (American and Japan standards are the same for the first order and second order but differ in the higher orders)

There are two different digital hierarchies (PDH hierarchies): one hierarchy based on 24 channels PCM system having a bit-rate of 1.544 Mbps (USA, CANADA, JAPAN) and other hierarchy based on 30 channels PCM system having bit-rate of 2.048 Mbps (Europe and some other countries). The multiplexing tree for different PDH hierarchies is shown in Fig. 2.

Now, we discuss the basic multiplexing method of 30 channels PCM systems. Fig. 3 shows the second-order multiplexing of 30 channels PCM systems. The four tributaries in Fig. 3 indicate four first-order 30 channels PCM systems. In Fig. 3, the tributaries are having a digital clock of 2.048 MHz each, but these clocks are asynchronous clocks having a slight variation of frequencies.

Multiplexing is possible only because variations of these clocks are within some specified limit and the multiplexing method is known as plesiochronous: not synchronous but not totally asynchronous.

For many years, optical fiber communication through PDH hierarchies was acceptable, but due to continuous developments of fiber cables, the scope for utilizing wide bandwidth of optical fiber was hampered by the existing PDH systems.

Now, we elaborate on the limitations of PDH multiplexing: since the tributary clocks are not

synchronized with one another, there is a danger of missing any information bit at the time of multiplexing which is known as slip.

In PDH multiplexing, slip is avoided by a method called justification: it is the process of changing the rate of the digital signal in a controlled manner to match it with a rate different from its own.

Briefly, it can be said that by justification, plesiochronous signals are synchronized at the same rate and are then multiplexed. In PDH multiplexing, positive justification is used. In each tributary, some extra bits are stuffed by which controlling is done in such a way that at the time of multiplexing there will be no loss of information in any of the tributaries.

In the multiplexer frame, there are three or five-time slots fixed for justification control bits (JCBits) and one-time slot fixed for justification bit (JBit), a particular sequence of JC Bits will indicate whether J Bit time slot carries information bit or simply a dummy bit.

The above process of multiplexing in PDH is very complex and multiplexing beyond 564.992 Mbps is not possible.

Continuous research work in fiber optics resulted in the manufacture of superior quality fiber cables which are suitable for transmission of much higher bit-rate which is beyond the capacity of PDH systems.

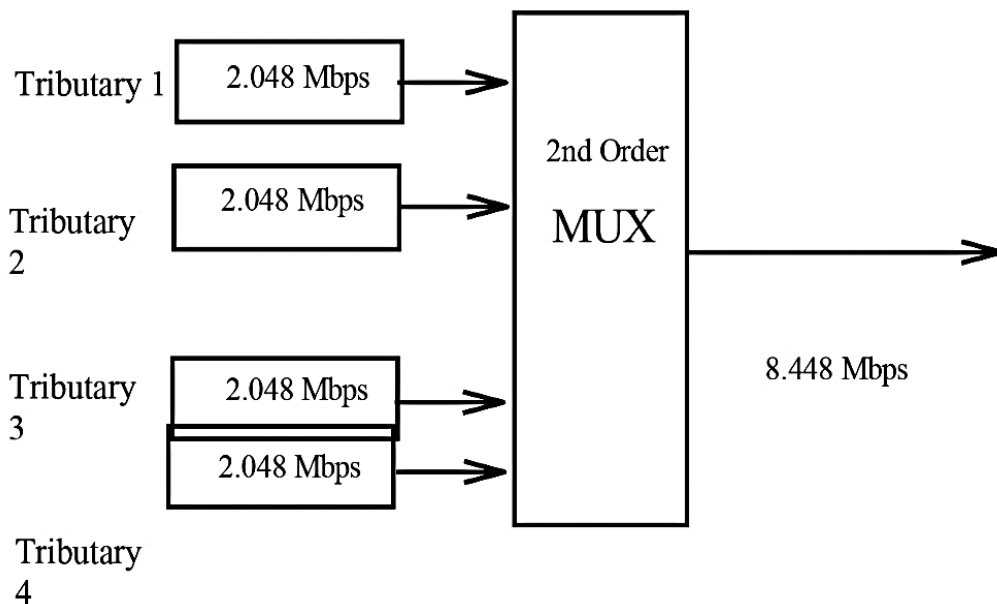

Fig. 3. Basic multiplexing method

5. SDH SYSTEMS

Research started for a multiplexing system where multiplexing would be controlled by a synchronous atomic clock. Attempts to formulate the standards for transmission of synchronous signals began in the USA at the beginning of 1984 by ANSI (American National Standard Institute). ANSI formulated SONET (Synchronous optical network) standards [8].

In 1985, the highest telecom authority of the USA accepted the SONET standards. These standards were formulated for the accommodation of North American Standard (USA/Canada) of the PDH hierarchy in the synchronous system.

In 1986, CCITT (now ITU-T), (CCITT stands for Consultative Committee for International Telephony and Telegraphy and ITU-T stands for International Telecommunication Union Telecommunication standardization system) [9], became interested in the SONET standard. CCITT proposed little changes to the SONET standard for the accommodation of all the three standards of PDH hierarchies (JAPAN standard, North American standard and European standard of PDH hierarchies) in the synchronous system.

The final agreement was reached in 1988 and CCITT working group XVIII came out with the recommendation of a synchronous optical network known as SDH (Synchronous Digital Hierarchy). SONET and SDH are both synchronous optical networks whereas SDH is a universal system and SONET is North American System.

Multiplexing in PDH is very complex and the PDH system can utilize only a fraction of the wide bandwidth available in optical fiber whereas multiplexing in SDH is much simpler and SDH systems can utilize much more bandwidth of the optical fiber than PDH.

Modern needs of FDDI (Fiber Distributed Data Interface), DQDB (Distributed-Queue Dual-Bus network), and ATM (Asynchronous Transfer Mode) can be fulfilled by SDH systems which are beyond the capabilities of PDH systems [10].

A simple block diagram of a SDH system is shown in Fig. 4 and the output bit-rate of the SDH multiplexer are as follows:

- STM-1: 155.52 Mbps
- STM-4: 622.08Mbps
- STM-16: 2488.32Mbps(2.5Gbps)

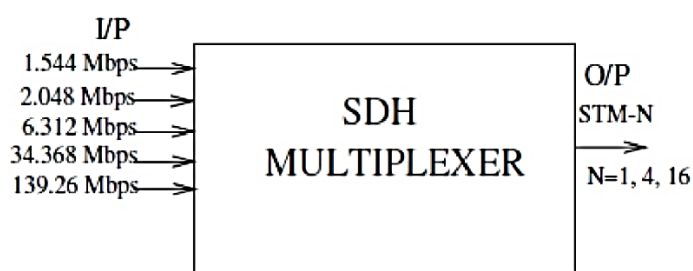

Fig. 4. SDH block diagram

Table 1. Combining structure of SDH Multiplexer

Input	Input Tributaries	Output
1.544Mbps	84	STM-1
	84xN	STM-N
2.048Mbps	63	STM-1
	63xN	STM-N
6.312Mbps	21	STM-1
	21xN	STM-N
34.368Mbps	3	STM-1
	3xN	STM-N
139.264Mbps	1	STM-1
	1xN	STM-N

Initially, the maximum bit-rate of transmission through SDH systems was 2.5 Gbps. Recent developments allow bit-rate up to 40 Gbps through SDH systems. SDH multiplexer accepts only first-order and second-order of Japan standards and first-order, second-order and third-order of North American standards of PDH systems. SDH multiplexer accepts first-order, third-order and fourth-order (does not accept second order) of European standards of PDH systems. Table 1 presents the combining structure of SDH multiplexer where N has value either one, or four, or sixteen.

An important point to note is that the input and output of a SDH multiplexer are bits only, but multiplexing is done considering bytes only.

In SDH multiplexer, in each frame (125 μ s), lower-order to higher-order, bytes are placed in rows x columns. The number of rows is fixed and it is nine, only the number of columns changes from lower-order frame to higher-order frame.

Before going for the multiplexing tree of SDH systems, we should know the full form of the following abbreviations:

- C: Container.
- VC: Virtual Container.
- TU: Tributary Unit.
- TUG: Tributary Unit Group.
- AU: Administrative Unit.
- POH: Path Overhead.
- SOH: Section Overhead.
- PTR: Pointer.

PTR, POH, SOH are overhead bytes used for proper identification and continuous monitoring, supervision, and control.

- C+POH:VC
- VC+PTR:TU/AU
- TUG: a combination of TUs
- AUG: combination of AUS

The multiplexing tree for SDH is shown in Fig. 5 and Fig. 6 shows the alternate path of SDH multiplexing for first-order, second-order and third-order of PDH tributaries bypassing the fourth-order [11].

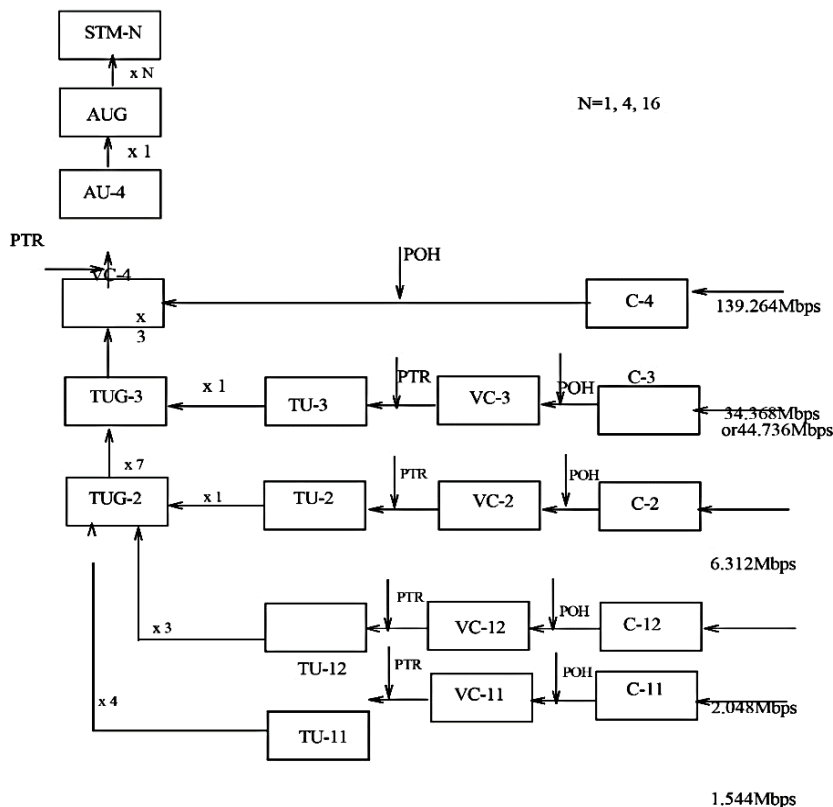

Fig. 5. Multiplexing tree for SDH

The STM-1 frame is shown in Fig. 7 and the specification of STM-1 frame is shown in Table 2. The section overhead (SOH) in the Fig. 7 have framing information, information for maintenance and performance monitoring, and other operational facilities. SOH has 9 rows and 9 columns. The first three rows of SOH indicate regenerator section overhead (R-SOH), the fourth row indicates AU pointers, and the last five rows indicate multiplex section overhead (M-SOH).

SDH multiplexer is controlled by a synchronized master clock. When the PDH tributaries are inserted in the SDH multiplexer sufficient number of stuffing bits are added with information bits to perfectly synchronize the PDH tributaries with the SDH system. According to

requirements, stuffing bits differ for different tributaries of PDH.

Before concluding the brief discussion on SDH, we must remember that though input to the SDH multiplexer are bits only, in the multiplexer frame they are assembled as bytes in rows x columns. The number of rows is fixed to 9 and columns vary in different order of multiplexing. An example of the frame structure of different stages of SDH multiplexing is shown in Fig. 8. Our above discussion shows that the maximum bit rate of transmission by SDH system is 2.5 Gbps (STM-16), but continuous developments enabled the modern SDH equipment to transmit bit-rate of 10 Gbps and 40 Gbps.

The hierarchy structure of SONET and SDH systems are given in Table 3.

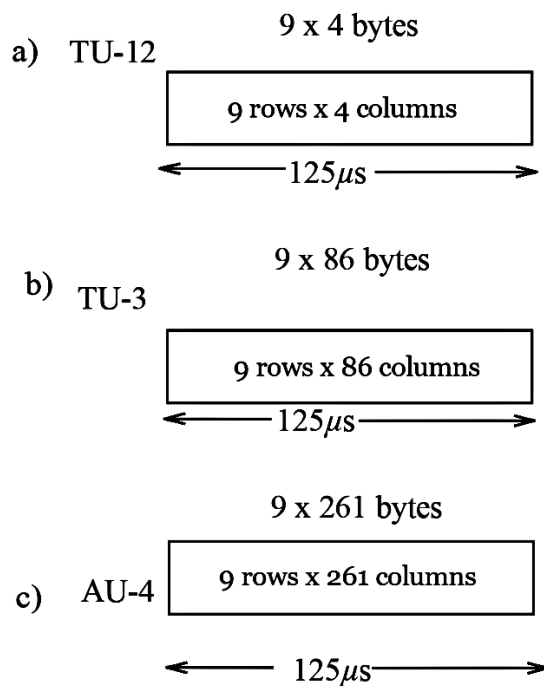

Fig. 8. Frame structure of different SDH multiplexing stages

Table 3. Hierarchy structure of SONET and SDH

SONETFRAMEFORMAT	SDHFRAMEFORMAT	LINEBITRATE(Mbps)
STS-1	STM-0	51.840(for Radio Systems)
STS-3	STM-1	155.520
STS-12	STM-4	622.080
STS-24	-	1244.160
STS-48	STM-16	2488.320(2.5Gbps)
STS-192	STM-64	9953.280(10Gbps)
STS-768	STM-256	39813.120(40Gbps)

6. A BRIEF DISCUSSION ON WAVELENGTH DIVISION MULTIPLEXING (WDM)

In this section, we discuss an overview of wavelength division multiplexing (WDM) [12]. It is similar to frequency division multiplexing (FDM) which was used in earlier communication systems and also used in radio communications.

Light is having different colors and each color has a different wavelength. If different wavelengths are properly multiplexed and are propagated through a single fiber then a single fiber communication will behave like a multiple fiber communication.

The idea of a WDM system was present earlier, but due to cost-effectiveness and lack of proper components, it was lying in the experimental stage. Due to regular developments of SONET/SDH systems and demand for more and more data bit transmission, vigorous research work started for WDM systems [13,14,15]. In this regard, the invention of an erbium-doped fiber amplifier (EDFA) [16] is very significant. EDFA amplifies signals at many different wavelengths simultaneously, regardless of their modulation scheme or speed.

At present there are two types of WDM systems: i) Coarse WDM (CWDM) [17] and ii) Dense WDM (DWDM) [16,18,19-22]. The CWDM system uses 8/16 number of channels (wavelengths) with cheaper transceivers and other components, and they are used only for short-distance communications. The DWDM system is used for long-distance communications. Its components are very costly but as it allows a very high bit-rate of transmission, it is cost-effective.

All the modern systems employing wavelength division multiplexing use DWDM for long-distance communications. DWDM uses C-band (1530 nm - 1565 nm) transmission window of the infrared spectrum. Channel plans vary, but a typical DWDM system uses 40 channels (40 wavelengths) at 100 GHz spacing or 80 channels (80 wavelengths) with 50 GHz spacing. Modern amplifiers enable the DWDM system to extend up to L-band (1565 nm - 1625 nm) where 160 channels (160 wavelengths) with 25 GHz spacing or 320 channels (320 wavelengths) with 12.5 GHz spacing can be used. In any digital communication, regeneration of the original

signal is essential. Considering the maximum allowable limit of attenuation and distortion, calculation is done to find out the maximum bit-rate of transmission of a digital system. Now, consider a DWDM system of eighty channels (eighty wavelengths) where for each channel the fixed frequency band of 50 GHz is allotted (which is known as fixed-grid of 50 GHz). Calculation was done to find out the maximum bit-rate of transmission through 50 GHz and it was found that maximum bit-rate of transmission is 400 Gbps only, but for transmission of 400 Gbps, requirement is high power amplifiers and modulators which are very costly. So, transmission of 400 Gbps by a DWDM channel, the system becomes very expensive. Cost-effective data transmission through 50 GHz is only 100 Gbps. So, now onwards, we will consider that a practical DWDM system allow maximum bit-rate of 100 Gbps per channel. A simple block diagram of a DWDM system is shown in Fig. 9.

In modern DWDM systems, instead of transceivers, a transponder is used. In a transceiver, the transmitter has electrical input and optical output, while the receiver has optical input and electrical output.

In a transponder, both input and output are optical. The optical transponder works as a regenerator which converts an optical signal into electrical form, then generates a logical copy of an input signal and uses this signal to drive a transmitter to generate an optical signal at the new wavelength (optical-electrical-optical). It has a prominent feature: it automatically receives, amplifies and then re-transmits a signal on a different wavelength without altering data/signal content.

An important feature of WDM systems is that in long-distance communications using WDM, it is very easy to add and drop some wavelengths at any intermediate station by using a wavelength add/drop multiplexer (WADM). A simple block diagram of a WADM is shown in Fig. 10.

In the brief discussion of WDM, we have narrated that the DWDM system can be extended up to 320 channels. Practically, a DWDM system works efficiently with 80 channels. For a DWDM system to extend up to 160 or 320 channels, components cost will be very high and due to some of the disadvantages of DWDM systems, research was continuously going on for

a better system with a higher bit-rate of transmission.

In our earlier discussion, we have narrated that DWDM systems work with 40 channels (40 wavelengths) or 80 channels (80 wavelengths) in C-band.

The following are the ITU-T standards for DWDM systems working in C-band:

- i) 40 wavelengths (40 channels) with fixed frequency spacing (fixed frequency grid) of 100 GHz.
- ii) 80 wavelengths (80 channels) with a fixed frequency grid of 50 GHz.

A practical 80 channels DWDM system when utilizing a 50 GHz frequency grid fully can transmit up to 100 Gbps.

For long-distance communication with wavelength add/drop multiplexer (WADM), requirements of different wavelengths will be

different; for example, one wavelength (channel) may require 10 Gbps of transmission, one may require 40 Gbps of transmission, next one may require 100 Gbps of transmission, and another may require very high bit-rate of 400 Gbps or 1 Tbps of transmission. A practical DWDM system can transmit up to 100 Gbps utilizing the full grid of 50 GHz and unable to transmit 400 Gbps or 1 Tbps through a single wavelength.

When a wavelength (channel) in the DWDM system transmits 100 Gbps, it utilizes the full 50 GHz grid, but at the time of transmission of 10 Gbps or 40 Gbps, only a portion of the fixed grid is utilized.

The above factors and continuous research work resulted in the evolution of a system that works on the principle of flexible grids (for less bit-rate of transmission grid will be small, for high bit-rate of transmission grid will be large and will be able to transmit bits in Tbps also) and this system is known as elastic optical networks which are based on orthogonal frequency division multiplexing.

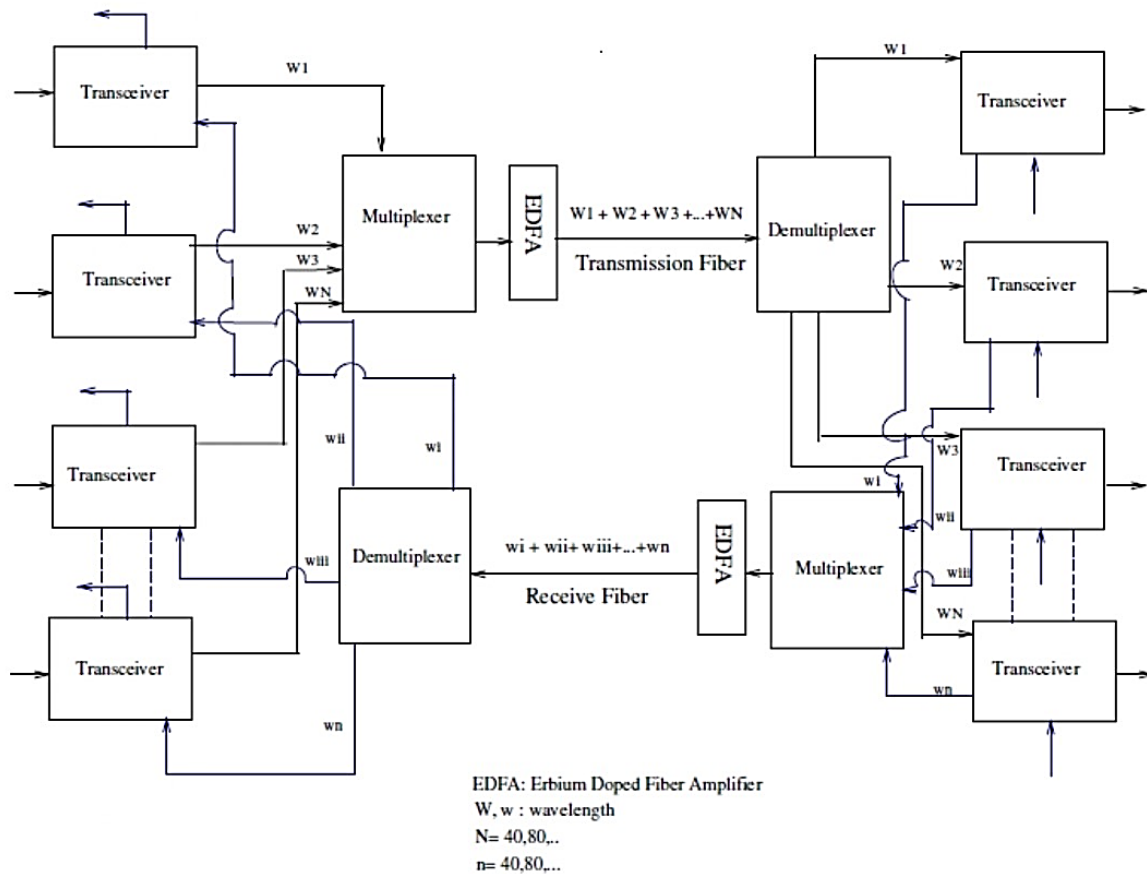

Fig. 9. A simple block diagram of a DWDM system

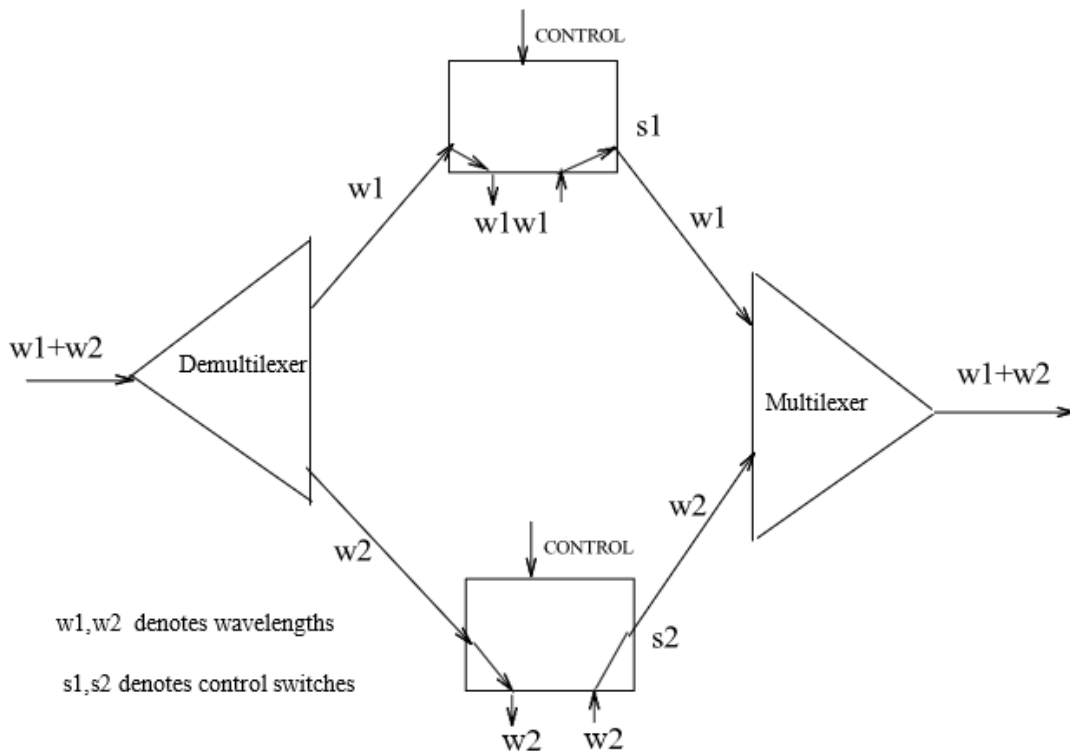

Fig. 10. A simple block diagram of wavelength add-drop multiplexer

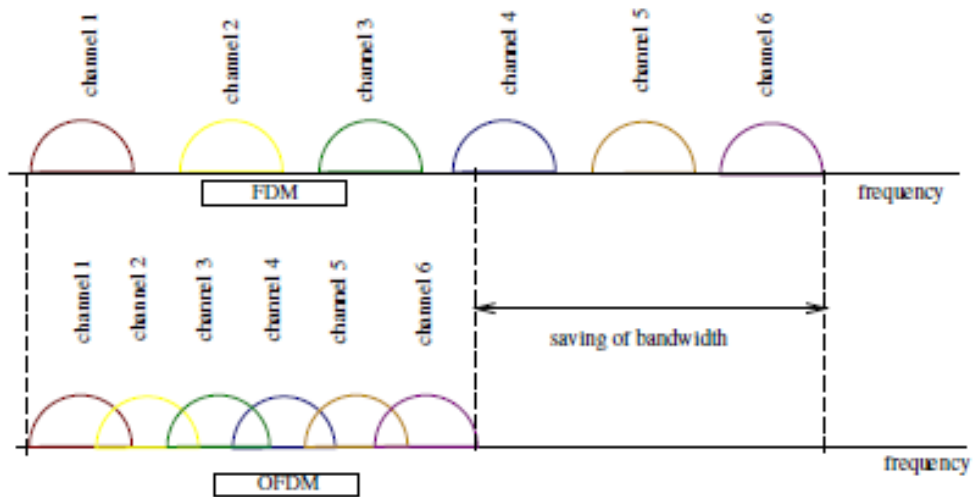

Fig. 11. Comparison of FDM and OFDM to illustrate bandwidth saving

7. ELASTIC OPTICAL NETWORKS

Elastic optical networks (EONs) are based on orthogonal frequency division multiplexing (OFDM). The difference between FDM and OFDM is shown in Fig. 11.

Optical OFDM distributes the data on several low data rate subcarriers (multiple carrier systems),

orthogonal signals are perpendicular to each other and the important property of orthogonal signals is that they do not interfere with each other [23].

In orthogonal frequency division multiplexing, the spectrum of adjacent sub-carriers can overlap since they are orthogonally modulated, increasing the transmission spectral efficiency.

Table 4. Wavelengths and frequency ranges of C and L Bands

	C-Band	L-Band
Wavelength range (nm)	1527.99 to1565.50	1565.50to1611.79
Frequency range (THz)	191.5to196.2	186.0to191.5

Moreover, optical OFDM can provide fine granularity capacity (the ability to increase a system capacity and performance) to connections by an elastic allocation of low-rate subcarriers according to connection demands.

Comparison between fixed-grid WDM optical network and flexible-grid elastic optical networks: Considering the attenuation, distortion and signal-to-noise ratio, the long-distance optical communication can avail only C-band and L-band of the electromagnetic spectrum. Table 4 shows the wavelength and frequency range of C and L bands [24].

- The total available spectrum in C-band is $196.2-191.5 = 4.7 \text{ THz}$ ($1 \text{ THz} = 10^{12} \text{ Hz}$).
- The total available spectrum in L-band is $191.5-186.0=5.5 \text{ THz}$.
- Total spectrum available with both C-band and L-band is $4.7+5.5=10.2 \text{ THz}$.

In WDM optical networks, we can go up to a maximum bit-rate of 400 Gbps per channel by using L-band and higher power amplifiers and modulators but total cost becomes very expensive. The cost-effective maximum bit-rate transmission for a WDM channel is 100 Gbps. WDM systems uses only C-band with fixed-grid of 50 GHz as standardized by ITU-T.

According to traffic demands when a WDM channel transmits 100 Gbps, it utilizes fully fixed grid of 50 GHz, but when traffic demands only 10 Gbps or 40 Gbps, invariably there will be wastage of the spectrum. An elastic optical network that works on orthogonal frequency division multiplexing can be flexible.

According to traffic demands, grid can be contracted or expanded and wastage of spectrum is totally avoided. The difference between WDM optical networks and elastic optical networks are shown in the Fig. 12. In convention, the 50 GHz fixed grids of WDM optical networks do not support bit rates of 400 Gbps at standard modulation formats. In EONs the spectrum can be divided up flexibly. Elastic optical network paradigm has support for 400 Gbps, 1 Tbps, and other high bit-rate demands

[25,26]. In WDM optical networks, a fixed spectrum is allocated even if there is not enough traffic in a channel, while in EONs spectrum is allocated according to the requested data-rate, and sub-wavelength service is directly supported in the optical domain. To provide super-wavelength service in WDM optical networks inverse multiplexing is used (break one data stream into several data-streams and transfer them through multiple independent WDM channels). In EONs, several OFDM channels are merged into a super-channel, they maintain spectrum orthogonality to save spectrum. In WDM optical networks, one type of transponder is used for one data rate. In EONs, a single type of a bit-rate variable and bandwidth-variable transponder is used for all types of services [27]. In OFDM high-speed data is transmitted through multiple parallel low-speed subcarrier signals. The optical OFDM multiplexing technique can be used to assign spectrum flexibly according to the required data rate, thus creating bandwidth-elastic optical paths [28].

The EONs architecture comprises bandwidth-variable transponders (BV-T), and bandwidth variable cross-connects (BV-OXC). Fig. 13 illustrates the architecture of an elastic optical network. The rate of transmission and modulation format can be adapted by the BV-T and it also facilitates flexible optical channels.

The optical cross-connect in EONs has a broadcast and select architecture as shown in Fig. 14. Here two traffic demands are represented by red and blue colours. The first traffic demand represented by red color is allocated three frequency slots 1, 2 and 3 while the second traffic demand represented by blue color is allocated slots 4 and 5. The traffic demands are groomed together so there is no guard band in between the two traffic demands, one guard band at the start and one at the end is allocated to avoid interference with other traffic demands. The bandwidth variable wavelength selective switches (BV-WSS) filters out the two traffic demands at their respective output channel. The main function of the optical cross-connects in EONs is switching optical paths between different channels and it supports

adding/dropping of optical signals at any of the intermediate nodes. The bandwidth-variable wavelength selective switches in a cross-connect provide filtering out of the optical signals to its intended output channel.

The optical path in EONs can expand and contract depending on the volume of the traffic and user requirement. The flexible spectrum allocation in EONs improves the spectrum efficiency and network-scalability to a higher extent. It supports both segmentation and aggregation of spectral resources and multiple data rates. EONs support fractional bandwidth

and establish an appropriate-sized optical transmission path according to the client requirement. EONs provide super-wavelength bandwidth (more than the bandwidth capacity of a wavelength) and support flexible spectrum allocation and fit mixed data-rate traffic demands.

To meet the increasing traffic demands, the EONs emerged as a technology which allocates bandwidth to traffic as per user's requirement. EONs support the flexible allocation of bandwidth and contribute to high-speed all-optical data communications.

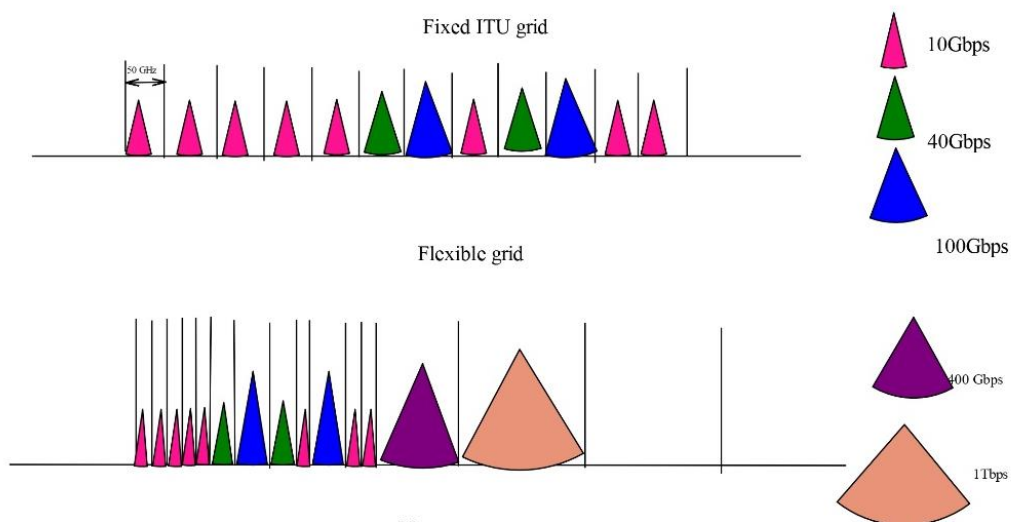

Fig. 12. Comparison of spectral widths in fixed and flexible grid optical networks

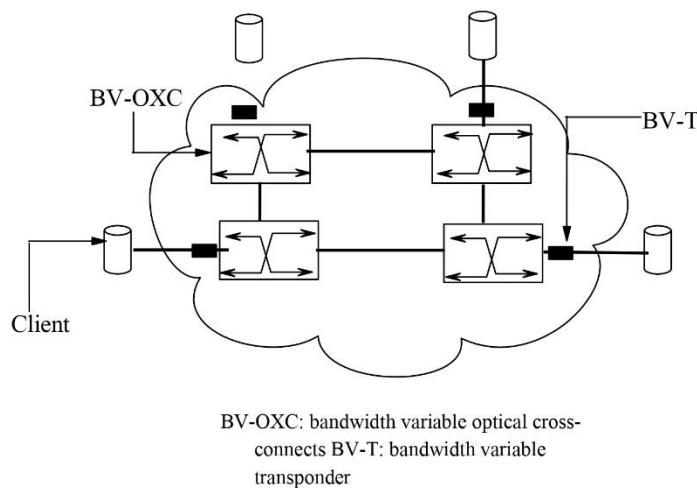
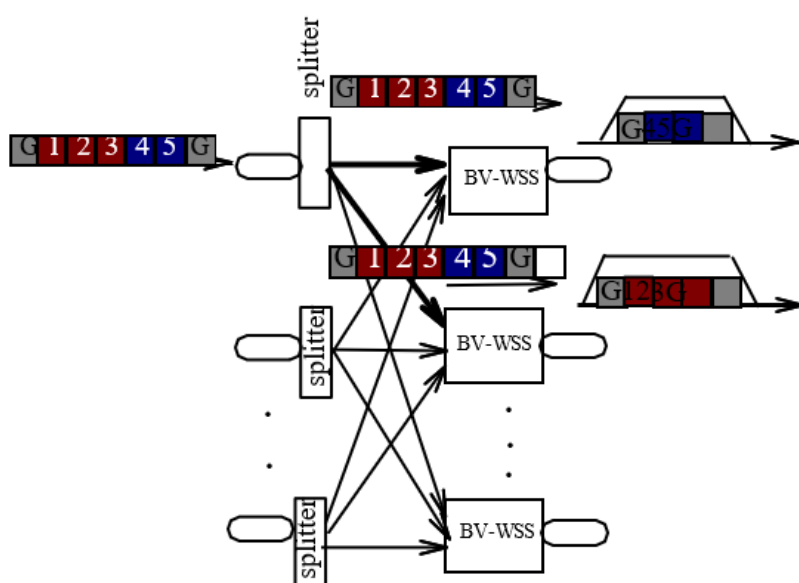

Fig. 13. A simple architecture of an elastic optical network system



BV-WSS stands for Bandwidth variable wavelength selective switches

Fig. 14. Broadcast and select architecture

In EONs, the optical spectrum is allocated to every traffic demand as per its requirement. In WDM optical networks the grid is fixed while EONs have a flexible grid so an optical path can expand and contract if required depending on traffic volume. EONs support scalability and enhance spectrum efficiency. EONs support segmentation, aggregation of spectrum slots, multiple data-rates, and elastic variation of allocated spectrum slots. The difference between WDM optical networks and EONs is illustrated in Fig. 15.

- **Sub-wavelength accommodation:** In WDM optical network networks optical paths are allocated a full wavelength capacity to the traffic demands even if the traffic demands do not utilize the full wavelength capacity. EONs support sub-wavelength accommodation of traffic demands. In EONs a traffic demand is assigned bandwidth as per its requirement. Optical paths are created by allocating bandwidth as per user demand and so sub-wavelength traffic demand accommodation can achieve cost-effectiveness and enhanced spectral efficiency.
- **Super-wavelength accommodation:** Super-wavelength traffic demands are the traffic demands having a capacity greater than a wavelength capacity. In fixed-grid WDM optical networks, many channels are

used for satisfying super-wavelength traffic demands. The insertion of spectral guard bands increases spectrum wastage.

- **Multiple data rate accommodation:** In EONs, there is support for multiple data-rates as there is flexible allocation of spectral resources in EONs. In fixed grid WDM optical networks, there is excess frequency spacing for lower data-rate traffic demands which causes bandwidth stranding. EONs accommodate various data-rates and increase spectrum efficiency.

In EONs, routing and spectrum allocation form an integral part. Routing is finding out a specified route from a source to a destination. Multicast traffic routing indicates finding dedicated paths from individual sources to multiple destinations. The process of spectrum allocation assigns spectral resources to traffic while not violating the spectrum allocation constraints. Routing and spectrum allocation is divided into two sub-problems:

- Routing
- Spectrum Allocation

Routing: Different routing approaches for transmitting traffic demands are briefly explained here.

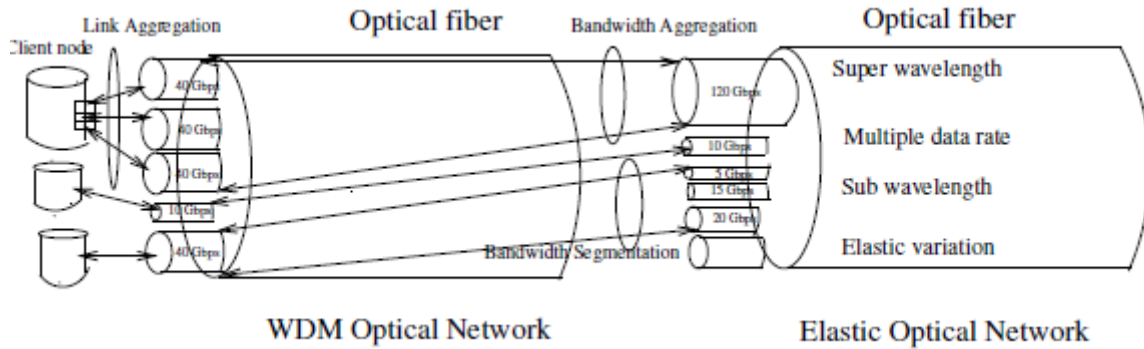

Fig. 15. Difference between WDM optical networks and EONs

Fixed Routing (FR): It is a method to choose the same fixed route for a traffic demand, such as fixed shortest-path routing. The shortest path route for each source-destination pair is calculated using a standard shortest path algorithm such as Dijkstra's algorithm and any traffic demand between the specified pair of nodes is established using the pre-determined route. This approach to route traffic demands is simple.

The drawback of this approach is that, if resources along the path are not available, it can potentially lead to high blocking probabilities. Fixed routing may not handle multiple link failures in the network. To handle multiple link failures, the routing scheme must either consider alternate paths to the destination or must be able to find the route dynamically.

Fixed Alternate Routing (FAR): If there is a source node S and its corresponding destination d1, the FAR approach finds multiple routes between them. Every node in a network has a routing table that comprises a list of routes to each destination from the source. The first shortest path is usually selected to be the primary route and the first alternate route must be link-disjoint with the primary route. Similarly, the second alternate route links disjoint to primary and the first alternate route.

Adaptive Routing (AR): In adaptive routing, the route from a source node to a destination node is chosen dynamically, depending on the network state. The traffic demand in progress is reflected in the current network state. In adaptive shortest-cost-path routing, traffic demand is blocked only during the unavailability of any route. In this type of routing there is lower blocking of traffic demands as

compared to both fixed and fixed-alternate routing.

Spectrum allocation for individual traffic demands: The routing and spectrum allocation problem has emerged from the routing and wavelength assignment (RWA) problem in WDM networks [26]. In EONs, elastic spectral allocation introduces some constraints mentioned in [29], which are discussed as follows:

Spectrum continuity constraint: All links on an optical path of a traffic demand should use the same range of spectral resources.

Spectrum Contiguous Constraint: A traffic demand must be assigned adjacent spectral resources.

Spectrum non-overlapping constraint: Two traffic demands should be assigned different spectral resources if they share any common link.

An issue relevant in EONs is fragmentation which is caused only when spectral resources are not suitable to be used because neither they are aligned nor they are contiguous. Several mechanisms such as spectrum-partitioning, a grouping of disjoint and non-disjoint traffic demands, multi-path routing and sweep retuning approach can eliminate or reduce spectral fragmentation in EONs.

In [30], the spectrum sweeping retuning approach is considered along with routing and spectrum allocation. Reduction in fragmentation will increase spectral efficiency [31].

The different policies for spectrum slot allocation for individual traffic demands:

- First-Fit Spectrum Allocation
 - Random-Fit Spectrum Allocation
 - Last-Fit Spectrum Allocation
 - First-Last-Fit Spectrum Allocation
 - Least-Used Spectrum Allocation
 - Most-Used Spectrum Allocation
 - Exact-Fit Spectrum Allocation
- **First-Fit Spectrum Allocation:** It selects the lowest indexed slot for allocating a traffic demand. When the traffic demand is terminated, the allocated slot is moved back to the list of free slots. This policy leaves a large number of spectrum slots available for future incoming traffic demands. It has low traffic blocking probability and computation complexity.
 - **First-Last-Fit Spectrum Allocation:** Spectrum can be partitioned into a different number of slot blocks. This policy selects the lowest indexed slots for odd-numbered partition and the highest indexed slots for even-numbered partitions, from the list of free slots.
 - **Most-Used Spectrum Allocation:** It allocates slots to traffic demand, which has been used by the most number of links in EONs. It ensures maximum spectrum reuse in EONs.
 - **Least used spectrum slot allocation:** It allocates slots to a traffic demand that has been used by the fewest links in EONs. If more than one free slots share the same minimum usage, then the first-fit policy is used to select a suitable spectrum slot.
 - **Random-Fit Spectrum Allocation:** On arrival of traffic demand, random-fit spectral allocation randomly selects a free slot and allocates it to the traffic demand. After allocating a slot to traffic demand, the list of free slots is updated by removing the used slots. When traffic demand is terminated, allocated slots are returned to the list of free slots. It reduces the possibility of multiple traffic demands selecting the same slots.
 - **Last-Fit Spectrum Allocation:** It attempts to select the highest indexed slot and allocates it to the traffic demand. When the traffic demand is terminated, the slot is added to the list of available slots.
 - **Exact-Fit Spectrum Allocation:** Starting from the beginning of the spectrum, this policy finds an exactly available block equal to the size of the slot block requested by the traffic demand. If an exact sized block is found then it allocates it to the traffic

demand. If an exact-sized spectrum block is not found then the first-fit spectrum allocation policy is used. Exact-fit spectrum allocation reduces fragmentation problem in EONs.

There are broadly two types of traffic demands one-to-one (or unicast) and one-to-many (or multicast). Multicast traffic is aided with the broadcast and select principle of a BVT, while BV-OXC is used to filter out signals which are not required. For multicast applications, light-tree-based optical paths are suitable for a spectrum-continuous type of transmission. Multicast service provisioning and spectrum allocation in EONs have been studied by several researchers [32,33,34].

Traffic grooming: Traffic grooming is the problem of grouping similar traffic demands and switching them as a whole.

In EONs, grooming helps because the slicing feature does not appear early in BVT, and grooming sub-wavelength services optimizes network resources to some extent. Another very important reason for grooming in EONs is that different traffic demands that are groomed together will not need guard band slots between their respective optical paths, thus reducing network spectrum usage considerably. Same source grooming is preferred over different source grooming as orthogonality cannot be maintained between optical paths in case of different source grooming [27].

If two multicast traffic demands have the same source and a similar set of destinations then they can be transmitted using the same light-tree, there is no need to add any guard bands between groomed traffic demands, only one guard band at the beginning and one at the end of the allocated spectrum is required.

Survivability in EONs: Any traffic demand passing through an EONs is susceptible to link failure, which results in connection disruption leading to tremendous data and revenue loss. To facilitate the reliable establishment of traffic, survivability (or protection) is considered in EONs. The survivability/protection approaches in EONs are either dedicated or shared and broadly classified into the following two categories: static and dynamic approaches. Both static and dynamic approaches are further classified into five sub-categories which are (i) tree-based protection, ii) ring-based protection, iii) path-based protection, iv) link/segment-based, and v) p-cycle-based.

Grooming policies are incorporated into the protection-based techniques to enhance the spectrum utilization efficiency. Grooming-based protection techniques in EONs have been studied in [35,36].

8. SPACE DIVISION MULTIPLEXING OPTICAL NETWORKS

Space division multiplexing (SDM) is also known as spatial division multiplexing. In frequency division multiplexing each channel is placed in a fixed frequency slot and neighboring channels are separated by a small frequency guard band. Similarly, in space division multiplexing, channels are placed in different space slots and neighboring channels are separated by a small space guard band.

The concept of SDM is not a new one and it is being available since the late seventies. Wireless communication uses space division multiplexing since long back. The need for SDM in optical fiber communications is only very recent. Optical fiber communication evolution is dependent on traffic demand and the cost-effectiveness of the system.

The elastic optical network has been working very efficiently with many advantages and it can transmit data-rate of 1 Tbps and more with cost-effectiveness. Regular technological developments in every sphere and exponential growth of Internet traffic demand data transmission in the range of 1 Pbs and more.

Long-distance optical fiber communication has progressed from time to time using only single-mode step index fiber. The multi-mode fiber was utilized only for short-distance communication. Maximum data transmission through a high-quality single-mode step index fiber with negligible loss depends on Shanon's theorem. Shanon's limit for maximum data transmission through a single-mode step index fiber is 100 Tbps.

As elastic optical networks use single-mode step index fiber, a flexible grid cannot be utilized for transmission of data-rate beyond 100 Tbps. Transmission of data-rate of 1 Pbs and more is possible and also cost-effective if space-division multiplexing is used.

Following are the basic requirements for SDM system for high data-rate transmission (1 pbps & more):-

- High quality multi-core fiber (MCF)
- High quality multi-mode fiber (MMF)

In multi-core fiber, different cores will serve as different space divisions and in multi-mode fiber, different modes will serve as different space divisions. When SDM uses multi-mode fiber, the system is also known as mode division multiplexing (MDM).

Multi-core Fiber (MCF): When the SDM system uses multicore fibers, the main problem is the inter-core crosstalk (XT). A way of crosstalk reduction is to assure that the fiber cores are well separated, but at the same time we cannot overlook the fiber reliability problems (particularly susceptible to fracture) and experiments in this regard have concluded that MCF diameter greater than nearly 200 μm should not be considered. Due to this limitation, the number of cores in an MCF is limited.

Research work is continuously going on different combinations of MCF:

- Uncoupled MCF with different number of cores
- Coupled MCF with different number of cores

The ultimate purpose is to transmit a huge number of bits to a very long distance without any distortion. Here, we must remember that recent technological developments allow us to eliminate inter-core crosstalk by utilizing coherent detection at the receiver.

Multi-mode Fiber: In SDM transmission with multi-mode fiber, distinguishable paths have sufficient spatial overlap and consequently susceptible to couple randomly among the modes during propagation. The modes will generally exhibit differential mode group delay (DMGD) and differential mode loss or gain. Crosstalk occurs when light is coupled from one mode to another and remains in the mode of detection. Inter-symbol interference (ISI) occurs when the crosstalk is coupled back to the original mode after propagating in a mode with a different velocity.

To keep the DGMD, crosstalk and ISI to a minimum level SDM transmission generally use Few Mode Fibers (FMF) and the corresponding distortion in the propagation path is neutralized by using multi-input multi-output (MIMO) digital signal processing and coherent receiver at the receiving end.

Number of modes	Single-core	Multi-core	
		Uncoupled-type	Coupled-type
Single	SMF 	Homogenous/Heterogenous 	
Few	FMF 	Few-mode MCF 	Hybrid structure
Multi	MMF 	Multi-mode MCF 	
			LMA fiber

LMA: Large Mode Area

Fig. 16. Classification of optical fibers

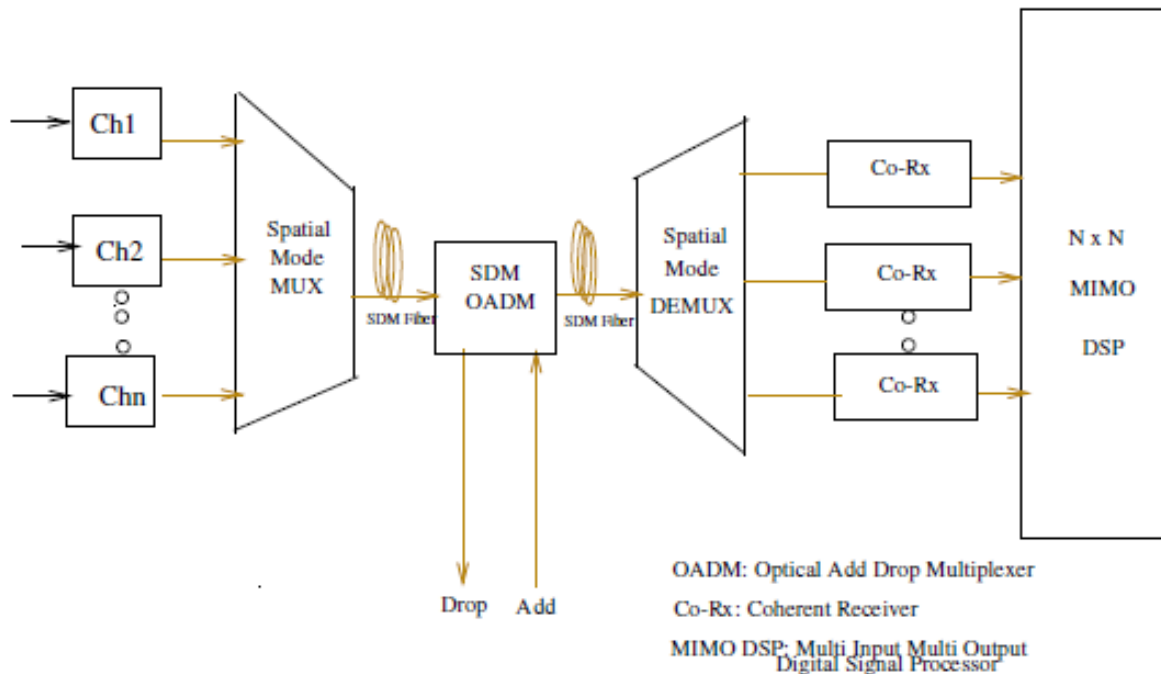

Fig. 17. SDM transmission system

In optical fiber communication, SDM is the most modern development and continuous research work is going for transmission of a higher number of Pbps to a very long-distance without any distortion. Two diagrams are given in Figs. 16 and 17. Fig. 16 shows the classification of optical fibers for SDM transmission and Fig. 17 shows SDM communication with coherent MIMO DSP technique.

9. CONCLUSION

We have briefly described the basic points of PDH, SDH, and WDM. We have provided a little elaborate discussion on EONs which uses recent optical network technologies. EONs cannot transmit data beyond 100 Tbps and future requirements of data transmission are in the range of Pbps and more. The future optical

network is space division multiplexing (SDM). In this article, we have narrated only the introductory part of SDM technology.

DISCLAIMER (ARTIFICIAL INTELLIGENCE)

Author(s) hereby declare that NO generative AI technologies such as Large Language Models (ChatGPT, COPILOT, etc) and text-to-image generators have been used during writing or editing of manuscripts.

COMPETING INTERESTS

Authors have declared that no competing interests exist.

REFERENCES

1. Hans Roder. Amplitude, phase, and frequency modulation. *Proceedings of the Institute of RadioEngineers*. 1931;19(12): 2145–2176.
2. Kenneth William Cattermole. *Principles of pulse code modulation*. *Advances in Electronics and Electron Physics*, Academic Press; 1969.
3. Wayne Tomasi. *Advanced electronic communication systems*. Prentice Hall PTR; 1993.
4. AndrewJViterbi. Aprocessing satellite transponder formulti pleaccess by low-rate mobile users. In *4th International Conference on Digital Satellite Communications*. 1979;166–174.
5. Dayou Qian, Ming-Fang Huang, Ezra Ip, Yue-Kai Huang, Yin Shao, Jun- qiang Hu, and Ting Wang. 101.7-tb/s(370x294-gb/s)pdm-128qam-ofdm transmission over 3x55-kmssm fusing pilot-based phase noise mitigation. In *National Fiber Optic Engineers Conference*, Optical Society of America; 2011.
6. MA Sorokina, SK Turitsyn. Regeneration limit of classical shannon capacity. *Nature communications*. 2014;5:3861.
7. Robert Xuebo Chen, William Xiao-Qing Huang. Synchronous ple- siochronous digital hierarchy transmission systems, US Patent. 1999, August 17;5:940,456.
8. Ralph Ballart, Y-C Ching. Sonet: Now it's the standard optical net- work. *IEEE Communications Magazine*. 1989;27(3):8–15.
9. Andrew Day. International standardization of bisdn. *IEEE LTS*. 1991;2(3):13– 20.
10. Nihal Kularatna. *Digital and Analogue Instrumentation: testing and mea- surement*. Number 11. IET; 2003.
11. Loay Alzubaidi. Path computation algorithms using SDH multiplexing mechanism. *J IJCSNS*. 2011;11: 53–56.
12. Siva Ram Murthy C, Mohan Gurusamy. *WDM optical networks: concepts, design, and algorithms*. Prentice Hall; 2002.
13. Hui Zang, Jason P Jue, Biswanath Mukherjee, et al. A review of routing and wavelength assignment approaches for wavelength-routed optical wdm networks. *Optical Networks Magazine*. 2000;1(1):47–60.
14. Biswanath Mukherjee. *Wdm optical communication networks: Progress and challenges*. *IEEE Journal on Selected Areas in communications*. 200;18(10): 1810–1824.
15. Keyao Zhu, Biswanath Mukherjee. A review of traffic grooming in wdm optical networks: Architectures and challenges. *Optical Networks Magazine*. 2003;4(2): 55–64.
16. RS Kaler, TS Kamal, Ajay K Sharma. Simulation results for dwdm systems with ultra-high capacity. *Fiber & Integrated Optics*. 2002;21(5):361–369.
17. Md Nooruzzaman, Osanori Koyama, Makoto Yamada, Yutaka Kat- suyama. Scalable single-fiber CWDM ring networks with stackable roadms. *Journal of Optical Communications and Networking*. 2013;5(8):910–920.
18. Md Nooruzzaman, Elbiازه Halima. Low-cost hybrid roadm architec- tures for scalable c/dwdm metro networks. *IEEE Communications Maga- zine*. 2016;54(8): 153–161.
19. Elsayed EE. Atmospheric turbulence mitigation of MIMO-RF/FSO DWDM communication systems using advanced diversity multiplexing with hybrid N-SM/OMI M-ary spatial pulse-position modulation schemes. *Optics Communications*. 2024;562:130558.
20. Elsayed EE. Performance enhancement of atmospheric turbulence channels in DWDM-FSO PON communication systems using M-ary hybrid DPPM-M-PAPM modulation schemes under pointing errors, ASE noise and inter-channel crosstalk. *Journal of Optics*. 2024;1-17.
21. Elsayed EE et. al. Investigations on wavelength-division multiplexed fibre/FSO PON system employing DPPM scheme. *Optical and Quantum Electronics*. 2022; 54(6):358.

22. Elsayed EE et al. Performance enhancement of M-ary pulse-position modulation for a wavelength division multiplexing free-space optical systems impaired by interchannel crosstalk, pointing error, and ASE noise. *Optics Communications*. 2000;475:126219.2020.
23. Konstantinos Christodoulouopoulos, Ioannis Tomkos, EA Varvarigos. Elastic bandwidth allocation inflexible ofdm-based optical networks. *Journal of Lightwave Technology*. 2011;29(9):1354–1366.
24. Neo Photonics: Overall fiber capacity increase through l-band optical components. <https://www.neophotonics.com/capacity-l-band-optical-components/>. Accessed:2020-10-4.
25. Masahiko Jinno, Hidehiko Takara, Bartlomiej Kozicki, Yukio Tsukishima, Yoshiaki Sone, Shinji Matsuoka. Spectrum-efficient and scalable elastic optical path network: Architecture, benefits, and enabling technologies. *IEEE Communications Magazine*. 2009;47(11):66–73.
26. Ori Gerstel, Masahiko Jinno, Andrew Lord, SJ BenYoo. Elastic optical networking: A new dawn for the optical layer? *IEEE Communications Magazine*. 2012;50(2):s12–s20.
27. Guoying Zhang, Marc De Leenheer, Biswanath Mukherjee. Optical traffic grooming in ofdm-based elastic optical networks, *Journal of Optical Communications and Networking*. 2012;4(11):B17–B25.
28. Cisco Visual Networking Index. Forecast and trends 2017-2022 whitepaper; 2019. Available:<https://www.cisco.com/c/en/us/solutions/collateral/service-provider/visual-networking-index-vni/white-paper-c11-741490.html>, Last accessed on 2019-12-03.
29. Bijoy Chand Chatterjee, Nityananda Sarma, Eiji Oki. Routing and spectrum allocation in elastic optical networks: a tutorial. *IEEE Communications Surveys & Tutorials*. 2015;17(3):1776–1800.
30. Xin Chen, Songwei Ma, Bingli Guo, Yan Wang, Juhao Li, Zhangyuan Chen, Yongqi He. A novel fragmentation-aware spectrum allocation algorithm in flexible bandwidth optical networks. *Optical Switching and Networking*. 2014;12:14–23.
31. Yawei Yin, Huan Zhang, Mingyang Zhang, Ming Xia, Zuqing Zhu, Stefan Dahlfort, SJ Ben Yoo. Spectral and spatial 2d fragmentation-aware routing and spectrum assignment algorithms in elastic optical networks. *Journal of Optical Communications and Networking*. 2013;5(10):A100–A106.
32. Shengru Li, Wei Lu, Xiahe Liu, Zuqing Zhu. Fragmentation-aware service provisioning for advance reservation multicast in sdeons. *Optics Express*. 2015;23(20):25804–25813.
33. Zheyu Fan, Yongcheng Li, Gangxiang Shen, Calvin Chun-Kit Chan. Dynamic resource allocation for all-optical multicast based on sub-tree scheme in elastic optical networks. In *Optical Fiber Communication Conference*, pages W2A–50. Optical Society of America; 2016.
34. Mehrdad Moharrami, Ahmad Fallahpour, Hamzeh Beyranvand, and Jawad A Salehi. Resource allocation and multicast routing in elastic optical networks. *IEEE Transactions on Communications*. 2017;65(5):2101–2113.
35. Menglin Liu, Massimo Tornatore, Biswanath Mukherjee. Survivable traffic grooming in elastic optical networks—shared protection. *Journal of Lightwave Technology*. 2013;31(6):903–909.
36. Sridhar Iyer. Traffic grooming with survivability and power-efficiency in software defined elastic optical networks. *Journal of Optics*. 2018;47(3):351–365.

Disclaimer/Publisher's Note: The statements, opinions and data contained in all publications are solely those of the individual author(s) and contributor(s) and not of the publisher and/or the editor(s). This publisher and/or the editor(s) disclaim responsibility for any injury to people or property resulting from any ideas, methods, instructions or products referred to in the content.

© Copyright (2024): Author(s). The licensee is the journal publisher. This is an Open Access article distributed under the terms of the Creative Commons Attribution License (<http://creativecommons.org/licenses/by/4.0>), which permits unrestricted use, distribution, and reproduction in any medium, provided the original work is properly cited.

Peer-review history:
The peer review history for this paper can be accessed here:
<https://www.sdiarticle5.com/review-history/119712>