



---

## **Natural Radioactivity Levels and Radiation Hazards in Shore Soil and Sediments along the Coast of Ndokwa East, Delta State, Nigeria**

**C. P. Ononugbo<sup>1\*</sup> and I. Ofuonye<sup>1</sup>**

<sup>1</sup>*Department of Physics, University of Port Harcourt, Rivers State, Nigeria.*

### **Authors' contributions**

*This work was carried out in collaboration between both authors. Author CPO designed the study, performed the statistical analysis, wrote the protocol, and wrote the first draft of the manuscript, managed the analyses of the study. Author IO managed the literature searches. Both authors read and approved the final manuscript.*

### **Article Information**

DOI: 10.9734/ACRI/2017/36213

Editor(s):

(1) Sanjeev Kumar, Department of Physics, Medical Physics Research Laboratory, D.A.V College, U.P., India.

Reviewers:

(1) R. D. Mavunda, University of Johannesburg, South Africa.

(2) Onuchukwu Chika, Chukwuemeka Odumegwu Ojukwu University, Nigeria.

Complete Peer review History: <http://www.sciencedomain.org/review-history/21220>

**Original Research Article**

**Received 18<sup>th</sup> August 2017**  
**Accepted 26<sup>th</sup> September 2017**  
**Published 3<sup>rd</sup> October 2017**

---

### **ABSTRACT**

Life on earth has developed under permanent exposure to radiation. Humans have no senses for ionizing radiation, therefore possible risks related to ionizing radiation were underestimated. The objectives of this study therefore is to measure the activity concentration of natural radionuclides in shore soil and sediment samples and determine the radiological health risk associated with exposure to them. The activity concentration of Natural Occurring Radioactive Materials (NORMs) in shore soil and sediments along the coast of Ndokwa East, Delta state were analyzed using a NaI(Tl) gamma ray spectrometric technique. The total average activity concentrations of radionuclides  $^{238}\text{U}$ ,  $^{232}\text{Th}$  and  $^{40}\text{K}$  were  $140.79\pm 18.3$ ,  $36.88\pm 2.10$  and  $621.25\pm 46.21$  Bqkg<sup>-1</sup> respectively in shore soil samples and  $189.62\pm 2.54$ ,  $53.47\pm 1.21$  and  $725.62\pm 21.03$  Bqkg<sup>-1</sup> respectively in shore sediment samples. Correlations made among these radionuclides prove the existence of secular equilibrium in the investigated shore soil. The absorbed dose rate calculated in soil and sediments were found to be twice the average safe value. The radiological health hazards such as gonads dose, excess lifetime cancer risk, internal and external hazard indices, activity

---

\*Corresponding author: Email: [onochinyere@yahoo.co.uk](mailto:onochinyere@yahoo.co.uk);

utilization and gamma representative indices calculated were higher than their respective safe values. Multivariate statistical analyses (Pearson correlation, cluster and factor analysis) were carried out between the parameters obtained from radioactivity concentration to know the existing relations.

*Keywords: Shore sediments; multivariate statistical analysis; spectrometry; Ndokwa East; annual effective dose.*

## 1. INTRODUCTION

Natural radioactivity is found within the natural environment all over the world. It exists in various geological formations like soil, rock, sediment, water, air and vegetation at varying concentration. Hence humans are exposed to some levels of radiation from the natural environment [1]. Some researchers [2,3] has pointed out some health implication of human exposure to radiation such as chronic lung diseases, acute leucopenia, anemia and necrosis of the mouth [2]. In addition, exposure to thorium can cause lung, pancreas, hepatic, bone, kidney cancers and leukemia [4]. In recent years, human exposure to ionizing radiation is one of the scientific subjects that attracts public attention since radiation of natural origin is responsible for most of the total radiation exposure of the human population [1].

Studies on the high background radiation areas in the world have been of prime importance for radiation risk estimation due to long term low-level whole body exposures of the public [5]. This high background radiation levels are due to high concentrations of naturally occurring radioactive materials in rocks, soil, sediments, water and air [3]. Among the various geologic formations, sediment plays predominant role in aquatic radioecology and in accumulating and transporting contaminants within the geographical area. It is the basic indicator of radiological contamination in the environment [4].

Marine sediments are the essential reservoir for natural and artificial radionuclide retention because of their diverse composition [6]. The uptake, mobilization, transport and re-deposition of natural radionuclide are complex processes that depends on physical and chemical parameters [5]. Sediment are naturally occurring material that is broken down by processes of weathering and erosion and is subsequently transported by the action of wind, water or force of gravity acting on the particle itself. It could consist of terrigenous materials which originate on land but may be deposited in either terrestrial,

marine or lacustrine environment or of sediments originating in the body of water [7]. Terrigenous material is often supplied by nearby rivers and streams or reworked marine sediment [1].

Natural radioactivity in soil comes from uranium and thorium series and natural potassium [3]. The study of the distribution of primordial radionuclide allows the understanding of the radiological implication of these elements due to gamma ray exposure of the body and irradiation of the lung tissue from inhalation of radon and its daughter [6]. Radiological studies have been made in beach sediments mainly in India because along its coastline, there are few monazite sand bearing placer deposits causing high background radiation levels at Kerala [7]. Also radiological studies in river sediments in Nigeria reported high values around oil and gas production facilities [8].

During the last few decades, the river Niger coastal areas of Ndokwa East, Delta State have experienced intense influx of effluents from operational oil and gas industries, aquaculture practices, transportation and boat construction activities [6,1]. The objective of this work is to evaluate the radiological health hazard due to natural radioactivity in river sediment and soil along the river Niger coast lines of Ndokwa East and using statistical software to establish the relationship between the radionuclides and the health parameters. The result of this work will serve as radiological data base of the area for future studies.

## 2. MATERIALS AND METHODS

### 2.1 Study Area

The study area comprises of five communities (Aboh, Abalagada Agwe-Etiti, Asemuku and Okpai) in Ndokwa east local government area which lies between latitude 5°45" N to 6°01"N and longitude 6°06"E to 6°20"E, it is bounded by the River Niger on the east, Isoko North Local Government Area in the south, Ughelli North, Ethiopie West, Ika North and South, Aniocha South and Oshimili South Local Government

Areas to the North. The study area is part of Niger Delta and it is underlain by sedimentary rocks, which consists mainly of yellow and white sand with pebbles, clay and sandy clay occur in lenses [9]. Three geological formation of Benin, Agbada and Akata formations occur in the area and they overlay one another, which has made the area viable for hydrocarbon exploration and development. The soil is deeply weathered, deeply reached, friable, and they lack distinct and well defined horizons. The soil has low silt and clay content, low cation exchange capacity and consequently low pH [10]. The major occupation of the Ndokwa east people is farming and fishing. It is also one of the major oil producers in the Niger Delta as it hosts major multinationals such as the Nigerian Agip oil Company (NAOC) and Sterling Global Oil Resources.

### 2.2 Sample Collection and Preparation

Soil samples were collected along the coastal region of river Niger using hand held auger from a depth of 5 cm from the surface while the sediment samples were collected using Peterson grab at all designated locations during low tide. Each sample has the weight of 3 kg. The collected samples of soil and sediment were air dried at room temperature in open air. The samples were placed in a black polyethene bags, well labelled and transferred to the laboratory.

The soil and sediment samples were oven dried at a temperature of 100-110°C for 24 hours and sieved through a 2 mm mesh size sieve to remove stone, pebbles and other macro-impurities. The homogenized samples was placed in a 250 g air tight PVC container. The inner lid was placed and closed tightly with outer cap. The container was sealed hermetically and externally using cellophane tape and kept for about 30 days to ensure equilibrium between radium and thorium and their progenies [11].

### 2.3 Gamma Ray Spectrometric Analysis

Sediment and soil samples were subjected to gamma spectral analysis with a counting time of 10,000 seconds. A 3" × 3" NaI(Tl) detector was employed with adequate lead shielding which reduces the background by a factor of about 95%. The concentration of various radionuclide of interest were determined in Bqkg<sup>-1</sup> using the count spectra. To determine the radioactivity content in sediment and soil samples, the detector was calibrated for efficiency using various energies of interest in the selected sample geometry. The gamma energies selected for U, Th and K are 1460 keV for <sup>40</sup>K, 1763 keV (from daughter product) for <sup>238</sup>U and 2614 keV (from daughter product <sup>208</sup>Tl) for <sup>232</sup>Th [12]. The detection limit of NaI(Tl) detector system for <sup>40</sup>K, <sup>238</sup>U and <sup>232</sup>Th are 8.5, 2.21 and 2.11 Bqkg<sup>-1</sup> respectively for a count time of 10,000 Seconds.



Fig. 1. Map of the study area

### 3. RESULTS AND DISCUSSION

#### 3.1 Activity Concentration of $^{40}\text{K}$ , $^{238}\text{U}$ and $^{232}\text{Th}$ in Soil and Sediment Samples

The activity concentration of  $^{40}\text{K}$ ,  $^{238}\text{U}$  and  $^{232}\text{Th}$  in soil and sediment samples are shown in Tables 1 and 2 respectively. The activities in  $\text{Bqkg}^{-1}$  of dry weight range and mean values (in brackets) for  $^{40}\text{K}$ ,  $^{238}\text{U}$  and  $^{232}\text{Th}$  in soil as shown in Table 1 are  $112.26 \pm 5.91$  to  $1535.01 \pm 79.56$  ( $621.25 \pm 46.21$ ), BDL to  $429.88 \pm 49.15$  ( $140.79 \pm 18.3$ ) and  $4.45 \pm 0.28$  to  $81.09 \pm 4.97$  ( $36.88 \pm 2.10$ )  $\text{Bqkg}^{-1}$  respectively. The wide variation in the activity concentrations of  $^{40}\text{K}$ ,  $^{238}\text{U}$  and  $^{232}\text{Th}$  in soil samples might be due to their presence and mobility in the coastal environment. From the result, the activity concentration of  $^{238}\text{U}$  in all the communities sampled was too high especially at MUKU 3 that recorded  $429.88 \pm 49.15$   $\text{Bqkg}^{-1}$ . This could be due to effluent from the oil drilling company and other oil and gas related activities in the area. This also affected the neighboring community ETIT11 which recorded activity concentration of  $^{238}\text{U}$  of  $364.74 \pm 42.91$   $\text{Bqkg}^{-1}$ . The results show that the mean activity of  $^{40}\text{K}$ ,  $^{238}\text{U}$  and  $^{232}\text{Th}$  in soil samples are higher than the world average values of 400, 35 and 30  $\text{Bqkg}^{-1}$  respectively [13].

From Table 2, the activity concentrations of  $^{40}\text{K}$ ,  $^{238}\text{U}$  and  $^{232}\text{Th}$  in sediment samples ranges and mean values in bracket are  $626.99 \pm 33.39$  to  $1337.50 \pm 69.33$  ( $725.62 \pm 21.03$ ),  $44.67 \pm 5.88$  to  $542.17 \pm 61.75$  ( $189.62 \pm 2.54$ ) and  $38.43 \pm 2.42$  to  $69.10 \pm 4.26$  ( $53.47 \pm 1.21$ )  $\text{Bqkg}^{-1}$  respectively. The variations in their activity concentrations are due to varying presence in marine environment and their physical, chemical and geochemical properties [7,2]. The result show that the average values of  $^{40}\text{K}$ ,  $^{238}\text{U}$  and  $^{232}\text{Th}$  in sediment are higher than the world average values of 400, 35 and 30  $\text{Bqkg}^{-1}$  respectively. According to the results obtained in this study, mean activity concentrations of the radionuclide increase according to the order  $^{232}\text{Th} < ^{238}\text{U} < ^{40}\text{K}$ . Concentration of  $^{238}\text{U}$  is found to be higher than  $^{232}\text{Th}$  in soil and sediment samples due to low geochemical mobility and insolubility nature of thorium in water [3]. Profiles of the activity concentration of the measured radionuclides with reference to their sampling points are presented in Figs. 2 (a-c). The wide variations in the activity concentrations as shown in the large values of

standard deviations is a measure of the spatial distribution of the radionuclides within the river. It also indicates the influence of physical and geochemical processes or the accumulation of radionuclides in the sediment within the river. The results show that the mean activity concentrations of the three radionuclides are higher when compared with their worldwide average values of 35, 30 and 400  $\text{Bqkg}^{-1}$  for  $^{238}\text{U}$ ,  $^{232}\text{Th}$  and  $^{40}\text{K}$  in soil and sediment samples as presented in UNSCEAR [14], report.

#### 3.2 Radium Equivalent Activity (Raeq)

The concept of radium equivalent allows a single index or number to describe the gamma output from different mixtures of uranium, thorium and potassium in soil and sediments samples from different locations of the coastal area. The radium equivalent activity, was calculated based on the assumption that 370  $\text{Bqkg}^{-1}$  of  $^{238}\text{U}$  or 259  $\text{Bqkg}^{-1}$  of  $^{232}\text{Th}$  or 4810  $\text{Bqkg}^{-1}$  of  $^{40}\text{K}$  produce the same gamma dose rate.  $R_{\text{aeq}}$  is related to the external gamma dose and internal dose due to radon and its daughters. The radium equivalent activity was calculated using equation 1 [15].

$$R_{\text{aeq}} = A_{\text{U}} + 1.43 A_{\text{Th}} + 0.07 A_{\text{K}} \quad (1)$$

where  $A_{\text{U}}$ ,  $A_{\text{Th}}$  and  $A_{\text{K}}$  are the activities concentrations of  $^{238}\text{U}$ ,  $^{232}\text{Th}$  and  $^{40}\text{K}$  in  $\text{Bqkg}^{-1}$  respectively.

From Table 1,  $R_{\text{aeq}}$  values ranges from 45.45 to 556.09  $\text{Bqkg}^{-1}$  with an average value of 147.83  $\text{Bqkg}^{-1}$ . It can be observed that the values at few locations MUKU3 (556.09  $\text{Bqkg}^{-1}$ ), ETIT11 (469.27  $\text{Bqkg}^{-1}$ ), OKPAL<sub>1</sub> (378.11  $\text{Bqkg}^{-1}$ ) and OKPAL<sub>2</sub> (421.35  $\text{Bqkg}^{-1}$ ) exceeded the maximum permissible limit of 370  $\text{Bqkg}^{-1}$  [10], though the average value of Radium equivalent activity is within the limit. The radium equivalent activity of the sediment as shown in Table 2 ranges from 172.0 to 719.94  $\text{Bqkg}^{-1}$  with an average value of 331.36  $\text{Bqkg}^{-1}$ .  $R_{\text{aeq}}$  in all the sampling communities are within the permissible limit of 370  $\text{Bqkg}^{-1}$  except in two locations, ABOH 1 (719.94  $\text{Bqkg}^{-1}$ ) and GADA 2 (600.55  $\text{Bqkg}^{-1}$ ).

#### 3.3 Evaluation of Radiological Hazard Parameters

##### 3.3.1 Absorbed dose rate (DR)

The absorbed dose rates due gamma radiations in air at 1 m above the ground surface for the

uniform distribution of the naturally occurring radionuclides ( $^{40}\text{K}$ ,  $^{232}\text{Th}$  and  $^{238}\text{U}$ ) were calculated on the basis of guidelines provided by UNSCEAR [7]. The conversion factors used to compute the absorbed dose rate (DR) in air per unit activity concentration in  $\text{Bqkg}^{-1}$  dry weight corresponds to  $0.462 \text{ nGyh}^{-1}$  for  $^{238}\text{U}$ ,  $0.604 \text{ nGyh}^{-1}$  for  $^{232}\text{Th}$  and  $0.042 \text{ nGyh}^{-1}$  for  $^{40}\text{K}$ . Therefore DR can be calculated using the following [11]:

$$\text{DR (nGyh}^{-1}) = 0.462 A_{\text{U}} + 0.604 A_{\text{Th}} + 0.042 A_{\text{K}} \quad (2)$$

where  $A_{\text{U}}$ ,  $A_{\text{Th}}$  and  $A_{\text{K}}$  are the activities concentrations of  $^{238}\text{U}$ ,  $^{232}\text{Th}$  and  $^{40}\text{K}$  in  $\text{Bqkg}^{-1}$  respectively.

The absorbed dose rate in coastal soil as shown in Table 3, ranges from 21.95 to 260.81  $\text{nGyh}^{-1}$

with a mean value of  $115.66 \text{ nGyh}^{-1}$ . The absorbed dose rate calculated from the activity concentration of radionuclides in sediment samples as shown in Table 4, ranges from 89.48 to  $477.35 \text{ nGyh}^{-1}$  with mean value of  $181.51 \text{ nGyh}^{-1}$ . The estimated mean value of absorbed dose rate in the studied samples of coastal soil and sediment are higher than the world average value of  $84.0 \text{ nGyh}^{-1}$ .

### 3.3.2 Annual effective dose equivalent (AEDE)

The annual effective dose rate equivalent resulting from the absorbed dose rates was calculated using the formula [14,11].

$$\begin{aligned} \text{AEDE (mSv}^{-1}) &= \text{DR (nGyh}^{-1}) \times 8760 \text{ hy}^{-1} \times 0.7 \\ &\times \frac{10^3 \text{ mSv}}{10^9 \text{ nGy}} \times 0.2. \\ &= \text{DR} \times 1.23 \times 10^{-3} \quad (3) \end{aligned}$$

**Table 1. Activity concentration of radionuclides in soil samples and its radium equivalent**

S/N	Sample location	GPS reading	Activity concentrations ( $\text{Bqkg}^{-1}$ )			$\text{Ra}_{\text{eq}}$ ( $\text{Bqkg}^{-1}$ )
			$^{40}\text{K}$	$^{238}\text{U}$	$^{232}\text{Th}$	
1	ABOH 1	N05 <sup>0</sup> 32.064 E006 <sup>31</sup> 5.54	122.9±6.4	39.2±4.5	4.5±0.3	54.1
2	ABOH 2	N05 <sup>0</sup> 32.576 E006 <sup>31</sup> 7.45	1412.3±73.7	89.8±11.5	56.5 ±3.5	189.4
3	ABOH 3	N05 <sup>0</sup> 33.194 E006 <sup>32</sup> 0.16	844.3±44.1	110.2±14.2	40.2±2.5	226.8
4	GADA 1	N05 <sup>0</sup> 34.345 E006 <sup>35</sup> 1.61	771.5±40.3	BDL	47.9±3.0	122.5
5	GADA 2	N05 <sup>0</sup> 35.225 E006 <sup>35</sup> 1.61	602.6±31.9	171.7±21.4	54.3±3.4	291.6
6	GADA3	N05 <sup>0</sup> 35.941 E006 <sup>35</sup> 1.26	130.2±6.9	30.99±4.1	4.8±0.3	47.0
7	MUKU 1	N05 <sup>0</sup> 39.381 E006 <sup>36</sup> 4.19	112.3±5.9	74.55±8.6	10.2±0.6	97.0
8	MUKU 2	N05 <sup>0</sup> 39.526 E006 <sup>36</sup> 2.77	140.3±7.3	25.43±3.05	7.13±0.4	45.5
9	MUKU 3	N05 <sup>0</sup> 39.697 E006 <sup>36</sup> 1.56	716.4±37.6	429.9±49.2	53.2±3.3	556.1
10	ETITI 1	N05 <sup>0</sup> 36.945 E006 <sup>36</sup> 7.53	811.5±42.6	364.7±42.9	33.38±2.1	469.3
11	ETITI 2	N05 <sup>0</sup> 37.197 E006 <sup>37</sup> 1.15	719.5±38.1	168.4±22.2	49.53±3.1	289.6
12	ETITI 3	N05 <sup>0</sup> 37.759 E006 <sup>37</sup> 1.77	752.3±40.3	BDL	19.92±1.30	81.2
13	OKPAI 1	N05 <sup>0</sup> 41.179 E006 <sup>35</sup> 9.13	1470.2±76.6	163.9±23.2	59.07±3.7	351.3
14	OKPAI 2	N05 <sup>0</sup> 41.371 E006 <sup>35</sup> 8.15	1258.1±66.1	245.1±31.3	31.46±2.00	378.1
15	OKPAI 3	N05 <sup>0</sup> 41.612 E006 <sup>35</sup> 8.17	1535.0±79.6	197.9±24.8	81.1±4.9	421.4
	<b>MEAN</b>		<b>621.3± 46.2</b>	<b>140.8±18.3</b>	<b>36.8±2.1</b>	<b>147.8</b>

**Table 2. Activity concentration of radionuclide in sediment samples**

S/N	Sample location	GPS reading	Activity concentrations (Bqkg <sup>-1</sup> )			Raeq (Bqkg <sup>-1</sup> )
			<sup>40</sup> K	<sup>238</sup> U	<sup>232</sup> Th	
1	ABOH 1	N05 <sup>0</sup> 33.194 E006 <sup>0</sup> 32.016	1216.3±63.6	542.2 ±61.8	64.8±4.0	719.9
2	ABOH 2	N05 <sup>0</sup> 32.576 E006 <sup>0</sup> 31.745	1272.9±67.0	25.4 ± 3.3	40.2 ±2.5	172.0
3	GADA 1	N05 <sup>0</sup> 37.034 E006 <sup>0</sup> 35.322	1337.5±69.3	107.8±13.8	69.1 ±4.3	300.2
4	GADA 2	No5 <sup>0</sup> 35.941 E006 <sup>0</sup> 35.126	984.7±51.6	445.6 ±51.7	60.3±3.7	600.6
5	MUKU 1	N05 <sup>0</sup> 40.005 E006 <sup>0</sup> 35.997	958.4±50.1	65.6±7.9	54.2±3.3	210.2
6	MUKU 2	N05 <sup>0</sup> 39.697 E006 <sup>0</sup> 36.156	627.0±33.4	190.6 ±25.4	41.2 ±2.6	293.4
7	ETITI 1	N05 <sup>0</sup> 38.946 E006 <sup>0</sup> 36.768	797.3 ±41.8	225.0 ± 26.8	63.8±3.9	290.6
8	ETITI 2	N05 <sup>0</sup> 37.759 E006 <sup>0</sup> 37.177	1072.7 ± 56.8	44.7±5.9	53.2±3.3	195.9
9	OKPAI 1	N05 <sup>0</sup> 41.867 E006 <sup>0</sup> 35.819	1285.8 ±67.1	112.7 ± 14.4	49.5±3.1	273.4
10	OKPAI 2	N05 <sup>0</sup> 41.612 E006 <sup>0</sup> 35.817	937.1 ± 49.8	136.9 ± 18.6	38.4±2.4	257.4
	<b>MEAN</b>		<b>725.±21.0</b>	<b>189.6±2.5</b>	<b>53.5±1.2</b>	<b>331.4</b>

**Table 3. Radiological parameters in shore soil samples along the Coast of Ndokwa East**

S/N	Sample location	DR (nGyh <sup>-1</sup> )	AEDE mSvh <sup>-1</sup>	AUI	AGD mSvh <sup>-1</sup>	H <sub>ex</sub>	H <sub>in</sub>	RLI	ELCR × 10 <sup>-3</sup>
1	ABOH 1	25.94	0.032	0.42	178.2	0.15	0.25	0.39	0.11
2	ABOH 2	134.91	0.17	1.63	957.0	0.75	0.99	2.105	0.59
3	ABOH 3	110.67	0.14	1.54	773.8	0.63	0.93	1.70	0.46
4	GADA 1	61.32	0.08	0.64	442.3	0.29	0.20	0.99	0.26
5	GADA 2	137.45	0.17	2.29	946.87	0.80	1.26	2.09	0.59
6	GADA3	22.70	0.03	0.36	156.84	0.13	0.21	0.34	0.10
7	MUKU 1	45.32	0.06	0.81	308.24	0.26	0.47	0.67	0.20
8	MUKU 2	21.95	0.03	0.33	152.43	0.13	0.19	0.33	0.09
9	MUKU 3	260.81	0.32	5.10	1775.60	1.52	2.68	3.87	1.12
10	ETITI 1	222.70	0.27	3.84	1523.10	1.28	2.27	3.31	0.99
11	ETITI 2	137.9	0.17	3.59	953.42	0.80	1.25	2.09	0.59
12	ETITI 3	43.63	0.05	0.30	319.48	0.233	0.233	0.70	0.19
13	OKPAI 1	173.16	0.21	2.35	1215.08	0.974	1.420	2.66	0.75
14	OKPAI 2	185.1	0.23	2.66	1283.78	1.045	1.71	2.78	0.79
15	OKPAI 3	121.74	0.15	1.95	1432.58	1.167	1.702	3.154	0.52
	<b>Mean</b>	<b>115.66</b>	<b>0.14</b>	<b>1.85</b>	<b>827.92</b>	<b>0.73</b>	<b>1.23</b>	<b>1.95</b>	<b>0.51</b>

The annual effective dose as shown in Table 3, ranges between 0.026 and 0.321 mSvy<sup>-1</sup> with a mean value of 0.142 mSvy<sup>-1</sup> while that obtained in the sediment samples ranges from 0.11 to 0.59 mSvy<sup>-1</sup>. In normal background area, the average annual outdoor effective dose from terrestrial radionuclides is 0.46 mSvy<sup>-1</sup> [10]. Therefore the obtained mean value from this studies are lower than the world average value

**3.3.3 Activity utilization index (AUI)**

The samples are also examined whether it facilitates the dose criteria when it is used as

building material. For this reason, the activity utilization index is calculated using the equation given by [1].

$$AUI = \left( \frac{A_U}{50 \text{ Bqkg}^{-1}} \right) f_u + \left( \frac{A_{Th}}{50 \text{ Bqkg}^{-1}} \right) f_{Th} + \left( \frac{A_K}{1500 \text{ Bqkg}^{-1}} \right) f_K \tag{4}$$

Where A<sub>Th</sub>, A<sub>U</sub> and A<sub>K</sub> are activity concentrations in Bqkg<sup>-1</sup> of <sup>232</sup>Th, <sup>238</sup>U and <sup>40</sup>K and f<sub>Th</sub> (0.604), F<sub>u</sub> (0.462) and f<sub>K</sub> (0.041) are fractional contributions to the total dose rate in air due to gamma radiation

from the actual concentrations of these radionuclides.

The calculated AUI values for all the samples of soil and sediment are presented in Tables 3 and 4 respectively. The values of AUI in soil ranges from 0.302 to 5.095 with an average of 1.854 while the activity utilization index calculated in sediment samples ranges from 0.081 to 1.12 with mean value of 0.25. The values obtained in soil samples were higher than the safe value of 2 and so should not be used as building materials but the values from sediment exhibit that  $AUI \leq 2$ , which corresponds to annual effective dose of  $0.3 \text{ mSvy}^{-1}$  [1].

### 3.3.4 Radiation hazard indices ( $H_{\text{ex}}$ and $H_{\text{in}}$ )

The two indices are that which represent the external and internal radiation hazards [15]. The external and internal index is obtained from Raeq expression through the supposition that its allowed maximum value (equal to unity) corresponds to the upper limit of  $Ra_{\text{eq}}$  ( $370 \text{ Bqkg}^{-1}$ ). The two indices can be defined as [16]

$$H_{\text{ex}} = \frac{A_U}{370 \text{ Bqkg}^{-1}} + \frac{A_{\text{Th}}}{259 \text{ Bqkg}^{-1}} + \frac{A_K}{4810 \text{ Bqkg}^{-1}} \leq 1 \quad (5)$$

$$H_{\text{in}} = \frac{A_U}{185 \text{ Bqkg}^{-1}} + \frac{A_{\text{Th}}}{259 \text{ Bqkg}^{-1}} + \frac{A_K}{4810 \text{ Bqkg}^{-1}} \leq 1 \quad (6)$$

Where  $A_U$ ,  $A_{\text{Th}}$  and  $A_K$  are the activity concentrations of  $A_U$ ,  $A_{\text{Th}}$  and  $A_K$  respectively. The index value must be less than to unity in order to keep the radiation to radiation hazard to be insignificant.  $H_{\text{ex}}$  in soil samples ranges from 0.125 to 1.516 with mean value of 0.729 while  $H_{\text{in}}$  in soil samples ranges from 0.194 to 2.678 with a mean value of 1.230. Also,  $H_{\text{ex}}$  calculated

in coastal sediments ranges from 0.49 to 1.97 with mean value of 0.93 while  $H_{\text{in}}$  ranges from 0.56 to 3.43 with mean value of 1.41. The external and internal hazard indices in soil and sediment samples exceeded the maximum value of unity in Muku, Etit, Okpai and Gada Communities and so the coastal soil and sediment from these communities cannot be used as building materials since it might pose radiological risks to the inhabitants.  $H_{\text{ex}}$  and  $H_{\text{in}}$  in Aboh community is less than the recommended value of unity (1). Therefore soil from Aboh area might not pose any significant radiological risks to the inhabitants.

### 3.3.5 Gamma radiation representative level index

Estimation of the level of gamma radioactivity associated with different concentrations of some specific radionuclides is known as the representative level index is given by Ravisankar et al. [17] as:

$$RLI = \frac{A_U}{150 \text{ Bqkg}^{-1}} + \frac{A_{\text{Th}}}{100 \text{ Bqkg}^{-1}} + \frac{A_K}{1500 \text{ Bqkg}^{-1}} \leq 1 \quad (7)$$

Where  $A_U$ ,  $A_{\text{Th}}$  and  $A_K$  are the activity concentrations of  $A_U$ ,  $A_{\text{Th}}$  and  $A_K$  respectively. The calculated RLI values for the samples under investigation are given in Table 3 and 4. The representative level index varies from 0.388 to 3.153 with an average value of 1.950 in soil samples and varies from 0.66 to 5.07 with mean value of 2.47. Values of  $RLI \leq 1$  corresponds to an annual effective dose of less than or equal to  $1 \text{ mSvy}^{-1}$ . The mean values of RLI in soil and sediment are higher than unity showing the unsafety of its use in construction of residential buildings.

**Table 4. Radiological parameters in sediment samples from coastal areas of Ndokwa East, Delta State**

S/N	Sample location	DR (nGyh <sup>-1</sup> )	AEDE mSvy <sup>-1</sup>	AUI	AGED mSvy <sup>-1</sup>	H <sub>ex</sub>	H <sub>in</sub>	RLI	ELCR × 10 <sup>-3</sup>
1	ABOH 1	340.69	0.42	0.26	2327.99	1.97	3.43	5.07	1.47
2	ABOH 2	89.48	0.11	0.13	646.23	0.49	0.56	0.66	0.39
3	GADA 1	147.71	0.18	0.12	809.13	0.84	1.13	2.30	0.64
4	GADA 2	283.55	0.35	0.2	1937.42	1.64	2.41	4.23	1.22
5	MUKU 1	103.29	0.13	0.12	730.16	0.59	0.76	2.06	0.45
6	MUKU 2	139.26	0.17	1.12	1388.08	0.81	1.32	2.10	0.60
7	ETITI 1	477.35	0.58	0.14	1759.38	1.02	1.63	2.67	2.06
8	ETITI 2	97.85	0.12	0.13	697.39	0.55	0.67	1.55	0.42
9	OKPAI 1	135.94	0.17	0.15	958.67	0.76	1.07	2.10	0.59
10	OKPAI 2	125.81	0.15	0.08	614.06	0.71	1.08	1.92	0.54
	<b>Mean</b>	<b>181.51</b>	<b>0.24</b>	<b>0.25</b>	<b>1186.85</b>	<b>0.93</b>	<b>1.41</b>	<b>2.47</b>	<b>0.83</b>

### 3.3.6 Excess lifetime cancer risk (ELCR)

The excess lifetime cancer risk (ELCR) is calculated using the equation 8 [15]. :

$$\text{ELCR} = \text{AEDE} \times \text{DL} \times \text{RF} \quad (8)$$

Where AEDE, DL and RF is the annual effective dose equivalent, duration of life (70 years) and radiation risk factor ( $\text{Sv}^{-1}$ ), fatal cancer risk per Sievert. For stochastic effects, ICRP 60 using value of  $0.05 \text{ Sv}^{-1}$  for the public [3]. The excess lifetime a cancer risk value ranges from  $0.091 \times 10^{-3}$  to  $1.124 \times 10^{-3}$  with a mean value of  $0.506 \times 10^{-3}$  in soil samples while ELCR calculated in sediment samples ranges from  $0.39 \times 10^{-3}$  to  $2.06 \times 10^{-3}$  with mean value of  $0.83 \times 10^{-3}$ . The average excess lifetime cancer risk (ELCR) calculated for all the soil and sediments samples are higher than the world average value of  $0.29 \times 10^{-3}$ [2]

### 3.3.7 Annual gonadal dose equivalent (AGDE)

The gonads, the bone marrow and the bone surface cells are considered as organs of interest by UNSCEAR [14] because they are the most sensitive parts of human body to radiation. An increase in AGED has been known to affect the bone marrow and destroys the red blood cells which are then replaced by white blood cells. This situation results in a blood cancer (leukemia).

AGED is calculated with given activity concentration of  $^{226}\text{Ra}$ ,  $^{232}\text{Th}$  and  $^{40}\text{K}$  (in Bq/kg) using the relation [14].

$$\text{AGED (mSv/yr)} = 3.09 C_U + 4.18 C_{\text{Th}} + 0.314 C_K \quad (9)$$

Where,  $C_{\text{Ra}}$ ,  $C_{\text{Th}}$ , and  $C_K$  are the radioactivity concentration of  $^{226}\text{Ra}$ ,  $^{232}\text{Th}$  and  $^{40}\text{K}$  (in Bq/kg) in soil samples respectively. AGED in soil samples ranges from 152.43 to 1775.60  $\text{mSvyr}^{-1}$  with an average value of  $827.92 \text{ mSvyr}^{-1}$ , while in sediment samples it ranges from 614.06 to 2327.99  $\text{mSvyr}^{-1}$  with mean value of  $1186.55 \text{ mSvyr}^{-1}$ , which is very much higher than the UNSCEAR value  $300.0 \text{ mSvyr}^{-1}$  reported as the world value [14].

## 3.4 Statistical Analysis of the Data

Basic descriptive statistics was used to illustrate the distributions and characteristics of the three radionuclides measured in soil and sediment

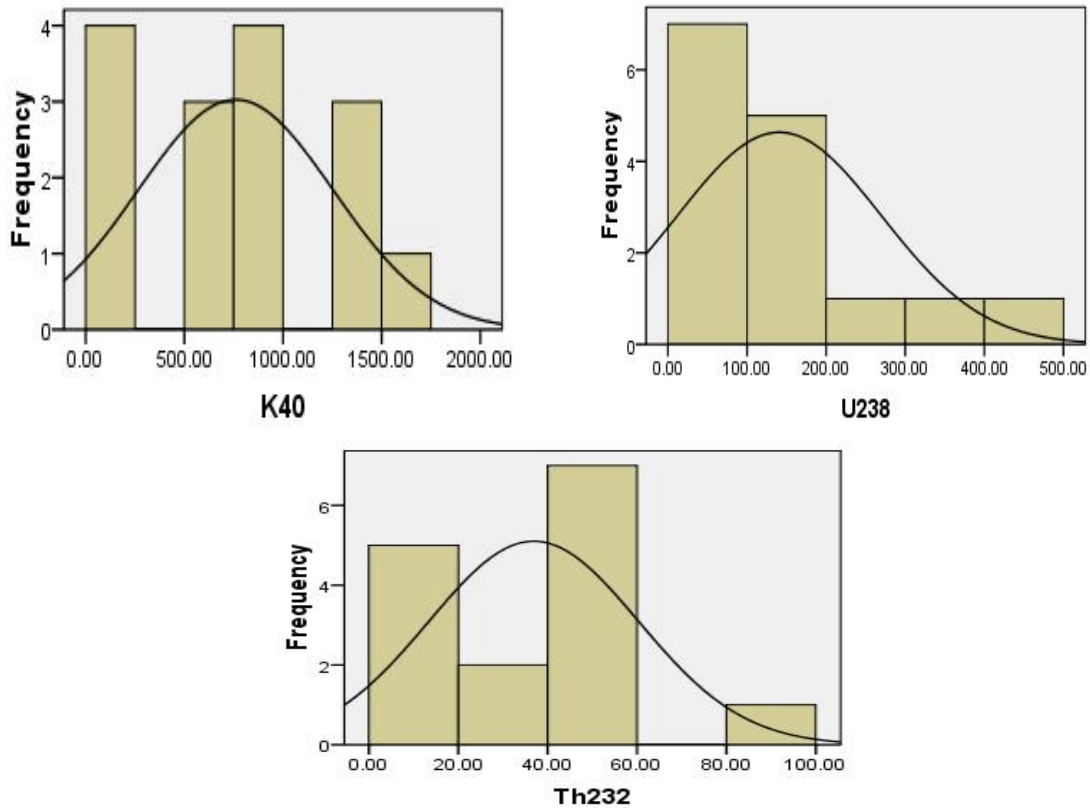
samples of Ndokwa east coastal region using commercially available statistics software package SPSS (version 16.0) for windows. Statistical parameters such as mean, standard deviation, geometric mean, variance, skewness, kurtosis, minimum and maximum were estimated and the summary presented in Table 4. Frequency distribution of  $^{40}\text{K}$ ,  $^{238}\text{U}$  and  $^{232}\text{Th}$  in soil from Ndokwa East coastline are shown in Fig. 2. In statistics, skewness represents the degree of asymmetry of a distribution around its mean [3,1].

As can be seen from Table 6 and Fig 3, all the radiological parameters have positive skewness indicating asymmetry distribution of the three radionuclides  $^{40}\text{K}$ ,  $^{238}\text{U}$  and  $^{232}\text{Th}$ .  $^{40}\text{K}$  and  $^{232}\text{Th}$  had a negative Kurtosis which shows a relatively flat distribution while  $^{238}\text{U}$  showed positive kurtosis. Pearson correlation analysis was also carried out to determine the mutual relationships and association between pairs of variables through the calculated linear correlation coefficient. A strong positive correlation among variables indicate similar source and behavior in the environment.

Results of the Pearson correlation coefficient among all the studied radiological parameters are presented in Table 5. It can be observed that positive correlation exist among the three radionuclides and all the radiation hazard parameters. Strong correlations were however observed between  $^{232}\text{Th}$  and  $^{40}\text{K}$  and also between  $^{232}\text{Th}$  and  $^{238}\text{U}$  while  $^{238}\text{U}$  is weakly correlated with  $^{40}\text{K}$ . This shows that their origin and behavior in the river are the same while weak positive relationship between  $^{238}\text{U}$  and  $^{40}\text{K}$  indicates that they may have the same origin but differs in behavior within the marine environment. All the radionuclide had significant contribution to gamma ray emission at the sampling points.

The objective of cluster analysis is the identification and classification of groups with similar character in a new group of observations. Each observation within each cluster is same but the clusters are dissimilar from each other. Similarity is a measure of distances between clusters relative to the largest distance between any two individual variables [11]. Cluster analysis was carried out through axes to identify similar characteristics among natural radioisotopes and radiological parameters in the soil and sediments. In CA, the average linkage method along with correlation coefficient distances was applied and the derived dendrogram was shown in

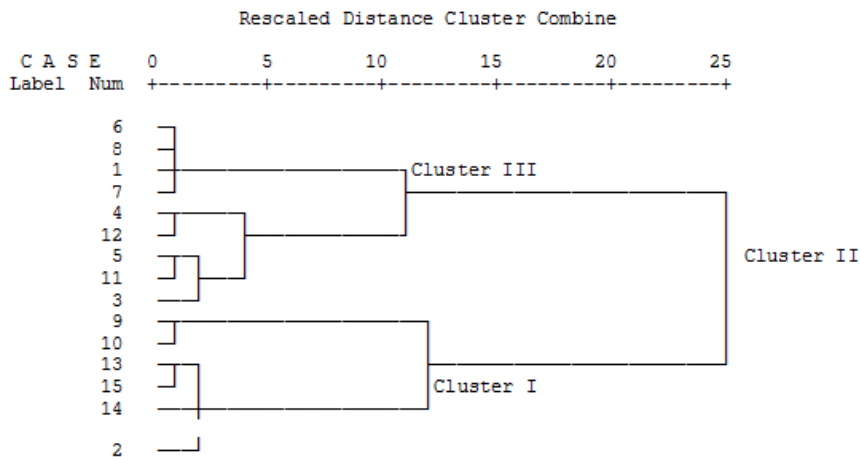




**Fig. 2. Frequency distribution of activity concentration of <sup>40</sup>K, <sup>238</sup>U and <sup>232</sup>Th in shore soil samples along Coast of Ndokwa East**

\*\*\*\*\* H I E R A R C H I C A L C L U S T E R A N A L Y S I S \*\*\*\*\*

Dendrogram using Average Linkage (Between Groups)



**Fig. 3. Dendrogram showing Cluster formation between radiological parameters of soil samples of Ndokwa East coast of Delta State**

Figs. 3 and 4. In this dendrogram, all 12 significant clusters. <sup>40</sup>K was in cluster 1 while <sup>238</sup>U and <sup>232</sup>Th with the radiological parameter

are grouped in cluster 2. The radionuclides  $^{238}\text{U}$  and  $^{232}\text{Th}$  were represented as one group with similar characteristics as they originated from  $^{238}\text{U}$  and  $^{232}\text{Th}$  series.  $^{40}\text{K}$  was identified in another group far from the

order radioisotopes and grouped closely with the group of grain size distribution [15]. The close relation between  $^{238}\text{U}$  and  $^{232}\text{Th}$  series members but not with  $^{40}\text{K}$  was in accordance with the results.

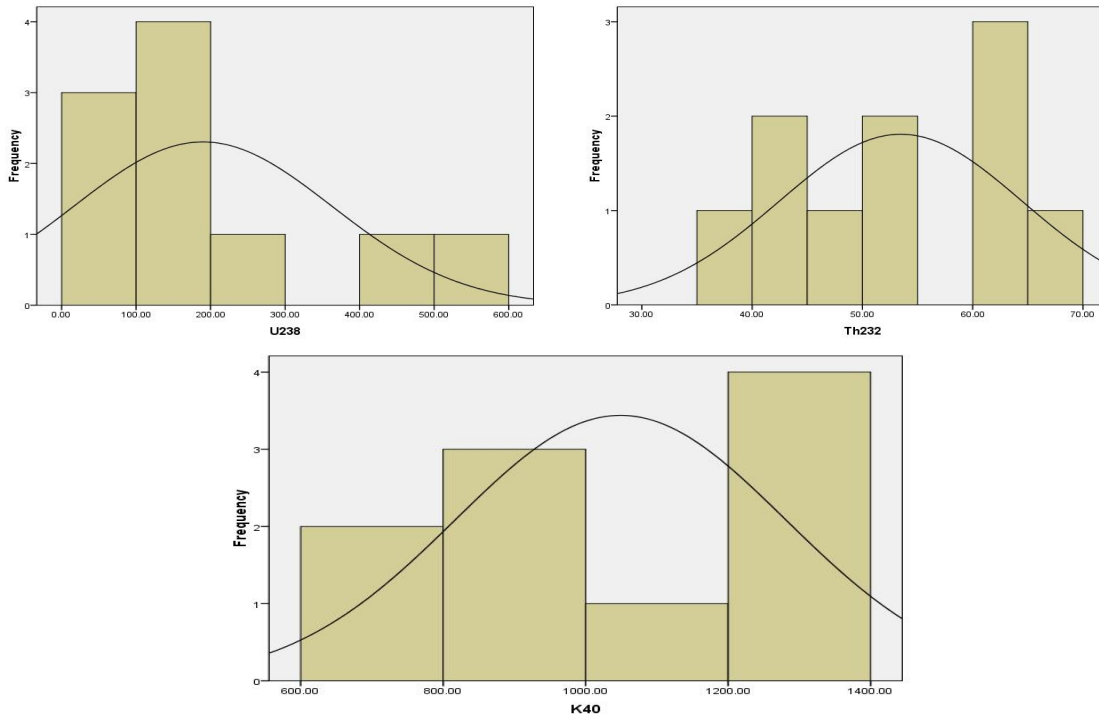


Fig. 4. Frequency Distribution of  $^{238}\text{U}$ ,  $^{232}\text{Th}$  and  $^{40}\text{K}$  in Sediment samples of Ndokwa East Coastal region

\*\*\*\*\* H I E R A R C H I C A L C L U S T E R A N A L Y S I S \*\*\*\*\*

Dendrogram using Average Linkage (Between Groups)

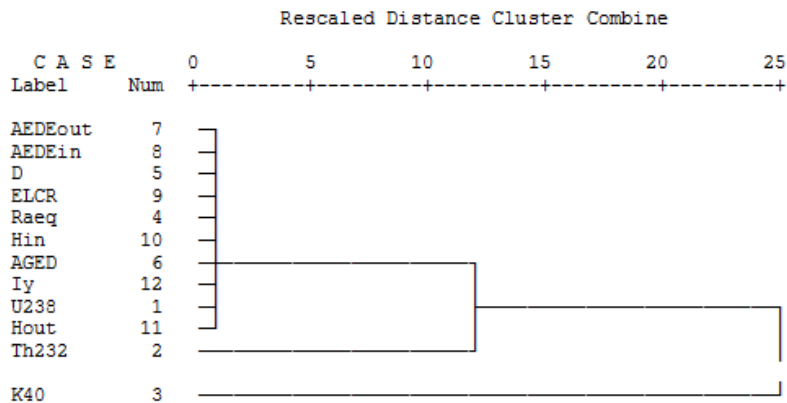


Fig. 5. Dendrogram showing Cluster formation between radiological parameters of sediment samples of Ndokwa East coast of Delta State.

**Table 5. Pearson correlation coefficient among radioactive parameters in soil of Ndokwa East coastal region**

	<b>40K</b>	<b>238U</b>	<b>232Th</b>	<b>Raeq</b>	<b>DR</b>	<b>AEDE</b>	<b>AUI</b>	<b>AGED</b>	<b>Hex</b>	<b>Hin</b>	<b>RLI</b>	<b>ELCR</b>
40K	1											
238U	0.355203	1										
232Th	0.819751	0.449322	1									
Raeq	0.598783	0.946446	0.686506	1								
DR	0.583425	0.932751	0.61686	0.952273	1							
AEDE	0.582651	0.932593	0.615398	0.951676	0.999992	1						
AUI	0.387987	0.943618	0.542164	0.920146	0.944043	0.94419	1					
AGED	0.692214	0.914236	0.742115	0.986981	0.960079	0.959479	0.898916	1				
Hex	0.652306	0.933854	0.715272	0.990841	0.963146	0.962594	0.914442	0.998173	1			
Hin	0.528649	0.979102	0.60222	0.985567	0.963597	0.963236	0.941387	0.975786	0.986408	1		
RLI	0.695986	0.910821	0.74969	0.986377	0.958463	0.957846	0.897417	0.999932	0.997774	0.973942	1	
ELCR	0.582782	0.932563	0.615751	0.951771	0.999993	1	0.944166	0.959558	0.96266	0.963252	0.95793	1

**Table 6. Statistical analysis of radionuclides in soil and sediment samples**

<b>Statistics</b>	<b>Sample</b>	<b><sup>40</sup>K</b>	<b><sup>238</sup>U</b>	<b><sup>232</sup>Th</b>
Minimum	Soil	112.26	0.00	4.45
	Sediment	626.99	25.41	38.43
Maximum	Soil	1535.00	429.88	81.09
	Sediment	1337.50	542.17	69.10
Mean	Soil	759.96	140.79	36.88
	Sediment	1.0490E3	1.8962E3	53.471
Variance	Soil	2.445E5	1.667E4	549.95
	Sediment	5.380E4	2.997E4	121.68
Skewness	Soil	0.139	1.028	0.004
	Sediment	-0.448	1.340	-0.099
Kurtosis	Soil	-1.004	0.530	-0.881
	Sediment	-0.620	0.818	-1.468
Range	Soil	1422.74	429.88	76.64
	Sediment	710.51	516.76	30.67
Std Deviation	Soil	4.94469E2	1.29112E2	2.34510E1
	Sediment	2.31947E2	1.73127E2	1.10307E1

*E2 means exponential 2*

#### 4. CONCLUSION

The activity concentration of  $^{40}\text{K}$ ,  $^{238}\text{U}$  and  $^{232}\text{Th}$  in soil and sediment samples from Ndokwa East, Delta State, were measured using NaI(Tl) gamma ray spectrometer. The activity concentration of  $^{40}\text{K}$ ,  $^{238}\text{U}$  and  $^{232}\text{Th}$  measured were higher than their world accepted value of 400.0, 35.0 and 30.0 Bqkg<sup>-1</sup> reported by UNSCEAR, [14] and it was used to calculate the radiation risk parameters. The absorbed dose rate calculated was found to be twice the value of 84.0 nGy<sup>-1</sup> reported as the world average. Other radiation health risk parameters such as gonads dose, excess lifetime cancer risk, internal hazard indices, activity utilization and gamma representative index were all higher than their respective maximum safe values in both soil and sediment. This shows that sediment and soil from sampled communities in Ndokwa East coastal area of river Niger should not be used as building materials in its present state.

Statistical analysis of the data show that a positive correlation exists between the three radionuclide showing same origin. Similar behavior of the three radionuclide  $^{40}\text{K}$ ,  $^{238}\text{U}$  and  $^{232}\text{Th}$  exists in their marine environment due to the fact that  $^{238}\text{U}$  and  $^{232}\text{Th}$ ,  $^{232}\text{Th}$  and  $^{40}\text{K}$  had strong correlation that existed between them while the behavior of  $^{238}\text{U}$  may differ due to weak correlation with  $^{40}\text{K}$ . The result of this study has clearly shown that there are buildup of radionuclides within the coastal environment of Ndokwa East due to industrial wastes that are discharged into the river via pipes from the oil and gas production activities and other maritime activities in the area. This result will serve as radiological baseline data for future studies.

#### COMPETING INTERESTS

Authors have declared that no competing interests exist.

#### REFERENCES

- Suresh Gandhi M, Ravisankar R, Rajalakshmi A, Sivakumar S, Chandrasekaran A, Pream Anand A. Measurement of natural gamma radiation in beach sediments of north east coast of Tamilnadu, India by gamma ray spectroscopy with multivariate statistical approach. *Journal of Radiation Research and Applied Sciences*. 2014;7:7-17.
- Taskin H, Karavus M, Ay P, Topuzoglu A, Hindirogin S, Karahan G. Radionuclide concentrations in soil and lifetime cancer risk due to the gamma radioactivity in Kirklareli, Turkey. *Journal of Environmental Radioactivity*. 2009;100:49-53.
- Isinkaye MO, Emelue HU. Natural radioactivity measurements and Evaluation of radiological hazards in sediment of Oguta Lake, South East Nigeria. *Journal of Radiation Research and Applied Sciences*. 2015;8:459-469.
- Suresh G, Ramasamy V, Meenakshisundaram V, Venkatachalapathy R, Ponnusamy V. A relationship between the natural radioactivity and mineralogical composition of the Ponnaiyar river sediments, India. *Journal of Environmental Radioactivity*. 2011;102:370-377.
- Muhmoud A. Dar, Mahmoud I. El Saman. The interaction of some radioelements activity patterns with some hydrographic parameters at the petroleum and phosphate regions in the Red sea, Egypt. *Journal of Radiation Radiation Research and Applied Sciences*. 2014;7:293-304.
- Uosif MAM, El-Taher A, Abbady AGE. Radiological significance of beach sand used for climatotherapy from Safaga, Egypt. *Radiation Protection Dosimetry*. 2008;131:331-339.
- United Nations Scientific Committee on the Effect of Atomic Radiation UNSCEAR. Sources and effect of ionizing radiation. Report to the General Assembly (NY: UN); 2000.
- Amekudzie A, Emi-Reynolds G, Faanu A, Darko EO, Awudu AR, Adukpo OK, Quaye LAN, Kpordzro R, Agyemang B, Ibrahim A. Natural radioactivity concentrations and dose assessment in shore sediments along the coast of greater Accra, Ghana. *World Applied Sciences Journal*. 2011; 13(11):2338-2343.
- Isinkaye MO, Shitta MBO, Oderinde MO. Determination of radionuclides and elemental composition of clay soils by gamma- and X-ray spectrometry. *Springer Plus*. 2013;2:74-79.
- Sivakumar S, Chandrasekaram A, Ravisankar R, Ravikumar SM, Prince Jebakumar P, Vijayagopal P, Vijayalakshmi I, Jose MT. Measurement of natural radioactivity and evaluation of radiation hazards in coastal sediments of

- east coast of Tamilnadu using statistical approach. Journal of Talibah University for Science. 2014;8:375-384.
11. Isinkaye MO, Oyedele EA. Assessment of radionuclides and trace metals in soil of an active designated municipal waste-dumpsite in Ado-Ekiti, Nigeria. Journal of International Environment and Applications. 2014;9(3):402-410.
  12. Jibiri NN, Emelue HU. Soil radionuclide concentration and radiological assessment in and around a refining and petrochemical company in Warri, Niger Delta, Nigeria. Journal of Radiological Protection. 2009;28:361-368.
  13. Farai IP, Isinkaye MO. Radiological safety assessment of surface-water dam sediments used as building materials in southwestern Nigeria. Journal Radiological Protection. 2009;29:85-93.
  14. United Nations Scientific Committee on the Effect of Atomic Radiation UNSCEAR; 2008.
  15. Degerlier M, Karahan G, Ozger G. Radioactivity concentrations and dose assessment for soil samples around Adana, Turkey. J. Environ. Radioact. 2008;99:1018-1025.
  16. ICRP. Radiation dose to patients from radiopharmaceuticals. Addendum 3 to ICRP Publication 53. ICRP Publication 106. Ann. ICRP. 2008;38:1-2.
  17. Ravisankar R, Vanasundari K, Chandrasekaran A, Rajalakshmi A, Suganya M, Vijayagopal P, Meenakshisundram V. Measurement of natural radioactivity in building materials of Tamilnadu, India using gamma ray spectroscopy. Appl. Radiat. isot. 2012;70:699-704.

© 2017 Ononugbo and Ofuonye; This is an Open Access article distributed under the terms of the Creative Commons Attribution License (<http://creativecommons.org/licenses/by/4.0>), which permits unrestricted use, distribution, and reproduction in any medium, provided the original work is properly cited.

*Peer-review history:*

*The peer review history for this paper can be accessed here:  
<http://sciencedomain.org/review-history/21220>*